



Clemas & Co Ltd

Industrial Cleaning Equipment
Sales - Hire - Service

TENNANT S12 SWEEPER OPERATOR MANUAL



Clemas & Co. Unit 5 Ashchurch Business Centre, Alexandra Way, Tewkesbury,
Gloucestershire, GL20 8NB.

Tel: 01684 850777

Fax: 01684 850707

Email: info@clemas.co.uk

Web: www.clemas.co.uk

CONTENTS

	Page		Page
SAFETY PRECAUTIONS	2	MAINTENANCE CHART	17
OPERATION	4	DAILY MAINTENANCE	17
OPERATOR RESPONSIBILITY	4	AFTER 50 HOURS OF OPERATION ...	17
MACHINE DESCRIPTION	4	AFTER 100 HOURS OF OPERATION .	17
MACHINE COMPONENTS	5	AFTER 200 HOURS OF OPERATION .	17
SAFETY DEVICES	6	MACHINE TROUBLESHOOTING	18
INITIAL STARTUP	6	SPECIFICATIONS	19
OPERATION	7	DIMENSIONS AND WEIGHT	19
ADJUSTING THE DRIVER'S SEAT	7	ELECTRICAL INSTALLATION	19
STARTING THE SWEEPER	7	ELECTRIC DRIVES	19
SWEEPING	8	TIRES	19
SAFETY INFORMATION	8	BRAKES	19
OPERATING THE MAIN BRUSH	8		
STOPPING THE MAIN BRUSH	8		
OPERATING THE SIDE BRUSH(ES) ...	8		
STOPPING SIDE BRUSH OPERATING .	8		
OPERATING THE VACUUM	8		
OPERATING THE FILTER CLEANER ...	8		
TURNING OFF THE SWEEPER	9		
EMPTYING THE DEBRIS HOPPER	9		
REMOVING THE DEBRIS HOPPER	9		
REINSERTING THE DEBRIS HOPPER .	9		
REPLACING THE FILTER	10		
POSITIONING THE FILTER	10		
INSTALLING THE FILTER	10		
CLEANING THE SWEEPER	10		
SIDE BRUSHES	11		
REMOVING THE SIDE BRUSH	11		
INSTALLING THE SIDE BRUSH	11		
ADJUSTING THE SIDE BRUSH	11		
MAIN BRUSH	12		
REMOVING THE MAIN BRUSH	12		
INSTALLING THE MAIN BRUSH	12		
SETTING THE MAIN BRUSH			
PATTERN	13		
CHECKING THE MAIN BRUSH			
PATTERN	13		
ADJUSTING THE MAIN BRUSH			
PATTERN	13		
BATTERIES	14		
CHARGING THE BATTERIES	14		
BRAKE	15		
ADJUSTING THE BRAKE	15		
BRAKE CHECK	15		
FREE MOVEMENT OF			
FRONT WHEEL	15		
CORRECT OPERATING			
OF BRAKE	15		
FURTHER SETTING POSSIBILITY .	15		
CIRCUIT BREAKERS	16		
STEERING	16		
BRUSH DRIVE	16		
TRANSPORTING THE MACHINE	16		

SAFETY PRECAUTIONS

The following symbols are used throughout this manual as indicated in the descriptions:



WARNING: To warn of hazards or unsafe practices that could result in severe personal injury or death.

FOR SAFETY: To identify actions that must be followed for safe operation of equipment.

The machine is suited to sweep disposable debris. Do not use the machine other than described in this Operator Manual. The machine is not designed for use on public roads.

The following information signals potentially dangerous conditions to the operator or equipment:



WARNING: Batteries emit hydrogen gas. Explosion or fire can result. Keep sparks and open flame away. Keep covers open when charging.



WARNING: Brush throws debris. Stop Motor before removing hopper.

FOR SAFETY:

1. Do not operate machine:
 - Unless trained and authorized.
 - Unless operation manual is read and understood.
 - In flammable or explosive areas unless designed for use in those areas.
 - In areas with possible falling objects.
2. Before starting machine:
 - Make sure all safety devices are in place and operate properly.
 - Check brakes and steering for proper operation.
3. When starting machine:
 - Keep foot on brake and the pedal in the top position.
4. When using machine:
 - Use brakes to stop machine.
 - Go slow on inclines and slippery surfaces.
 - Use care when reversing machine.
 - Do not carry riders on machine.
 - Always follow safety and traffic rules.
 - Report machine damage or faulty operation immediately.
5. Before leaving or servicing machine:
 - Stop on level surface.
 - Set parking brake.
 - Turn off machine and remove key.
6. When servicing machine:
 - Avoid moving parts. Do not wear loose jackets, shirts, or sleeves when working on machine.
 - Block machine tires before jacking up machine.
 - Jack up machine at designated locations only. Block machine up with jack stands.
 - Use hoist or jack that will support the weight of the machine.
 - Wear eye and ear protection if using pressurized air or water.
 - Disconnect battery connections before working on machine.
 - Avoid contact with battery acid.
 - Use Tennant supplied or equivalent replacement parts.
7. When loading/unloading machine onto/off truck or trailer:
 - Turn off machine.
 - Use truck or trailer that will support the weight of the machine.
 - Use winch. Do not drive the machine onto/off the truck or trailer unless the load height is 380 mm or less from the ground.
 - Set parking brake after machine is loaded.
 - Block machine tires.
 - Tie machine down to truck or trailer.

The following safety labels are mounted on the Machine in the locations indicated. If any Label becomes damaged or illegible, install a new label in its place.

FOR SAFETY LABEL - LOCATED ON THE SIDE OF THE OPERATOR COMPARTMENT.



BATTERY CHARGING LABEL - LOCATED IN THE BATTERY COMPARTMENT.



FLYING DEBRIS LABEL - LOCATED ABOVE THE DRIVE AXLE.

OPERATION

OPERATOR RESPONSIBILITY

- The operator's responsibility is to take care of the daily maintenance and checkups of the machine to keep it in good working condition. The operator must inform the service mechanic or supervisor when the maintenance intervals are required as stated in the *MAINTENANCE* section of this manual.
- Read this manual carefully before operating this machine.

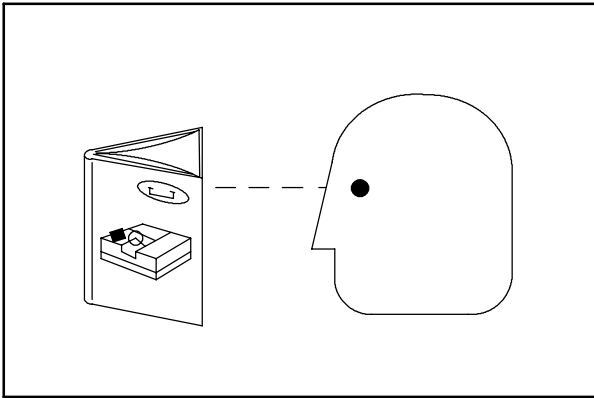

07324

MACHINE DESCRIPTION

This sweeper is driven by electric motors.

This model operates by using a pivotable side brush to direct the debris to the sweeping brush. The sweeping brush projects the debris up into the dust container.

Two side brushes may optionally be installed. If necessary, the dust stirred up by the sweeping brush is caught by the dust suction unit in a panel filter inside the machine. The panel filter is cleaned by an electrically controlled filter cleaning device.

FOR SAFETY: Do not operate machine, unless operation manual is read and understood.

- Check the machine for shipping damage. Check to make sure the machine is complete per shipping instructions.
- After operation, follow the recommended daily and hourly procedures stated in the *MAINTENANCE CHART*.

MACHINE COMPONENTS

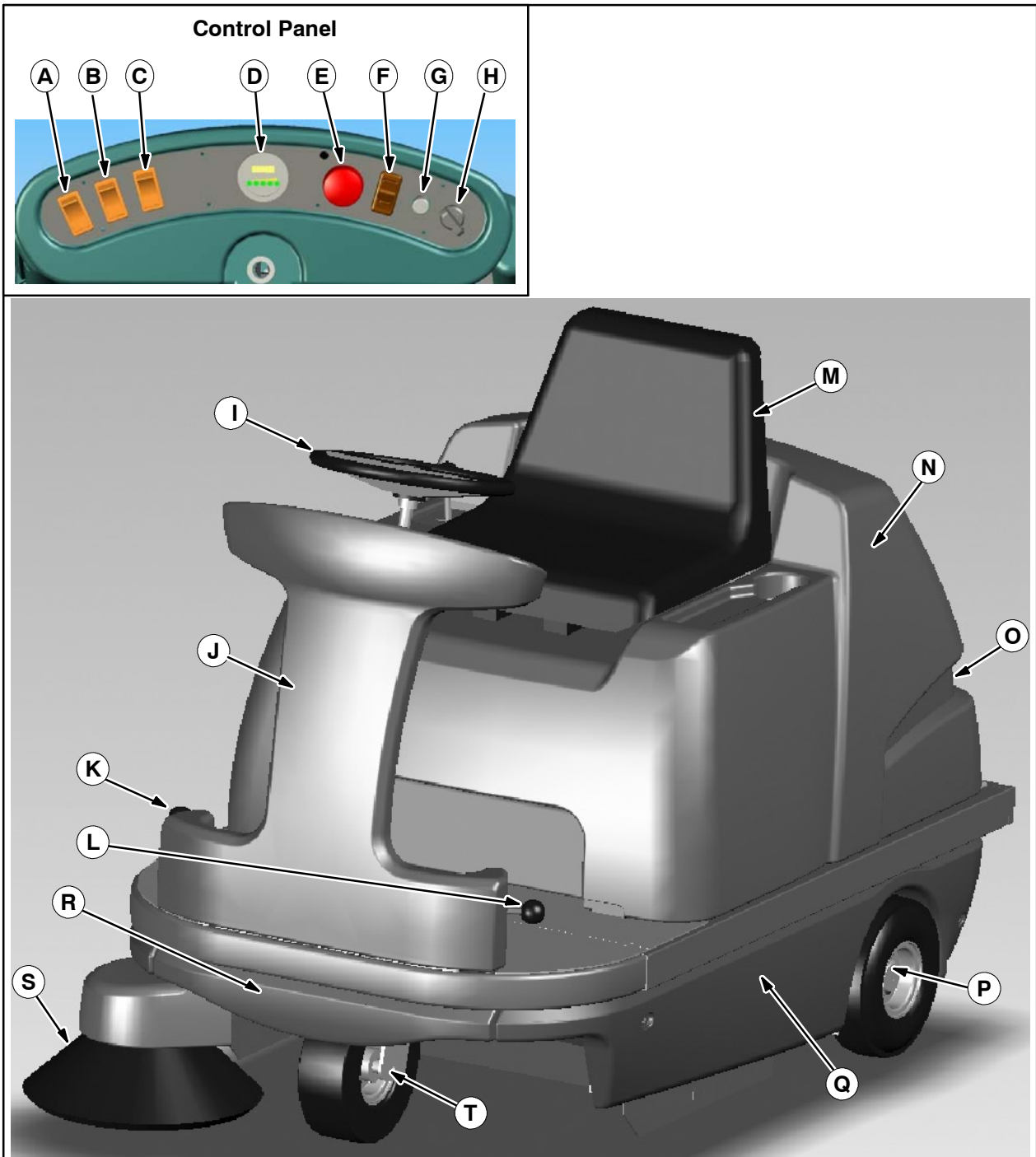

- A. Side brush switch
- B. Main brush switch
- C. Vacuum/filter cleaner switch
- D. Battery condition display
- E. Emergency stop switch
- F. Directional switch
- G. Horn push button
- H. Key switch
- I. Steering wheel
- J. Front console

- K. Side brush lever (standard right)
- L. Side brush lever (optional left)
- M. Driver's seat
- N. Main cover
- O. Debris hopper
- P. Drive wheel
- Q. Side cover
- R. Front trim panel
- S. Pivotal side brushes
- T. Front wheel with drum brake

SAFETY DEVICES

This sweeper can only be started if:

- the ignition key is set to the ON position;
- the emergency stop switch is deactivated.

If the directional switch is set to reverse motion, an audible signal is heard.

INITIAL STARTUP

This standard sweeper does not include batteries or charger. The batteries and charger are optional. If the batteries are not installed, perform the following procedure.

1. Open the transport packaging, disengage the seat switch cable and the main cover prop rod.
2. With the help of an assistant, remove the main cover by lifting it at the rear handle and at the front of the seat support.
3. Install the batteries.
4. Connect the batteries. Refer to technical data circuit diagram.
5. Replace the main cover.
6. Install the side brush
(See: Installing the Side Brushes).

The Sweeper is ready for use.

- Ramp is not included.

NOTE: Use a unit ramp. The ramp must be designed in such a way as to allow the front wheel as well as the drive wheels to travel across it. If this is not observed, damages to the sweeper mechanics may occur.

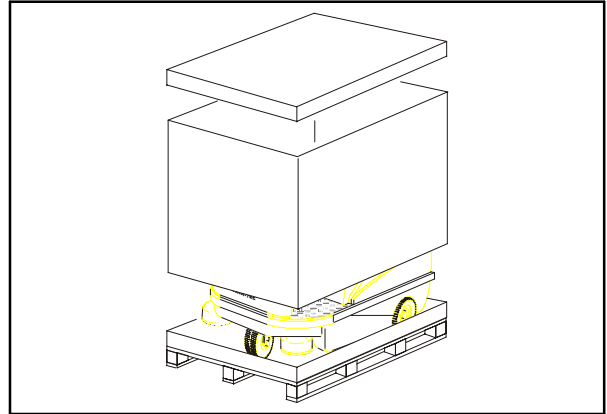

If the drive pedal is activated during the starting procedure, the machine will not propel if the driver's seat is not weighed down.

OPERATION

ADJUSTING THE DRIVER'S SEAT

Loosen the seat adjuster and shift the seat on the seat support to adjust the seat position.

STARTING THE SWEEPER

1. Sit down in the driver's seat.

NOTE: The Sweeper cannot be driven if the driver's seat is not weighed down.

2. Check the position of the directional switch.

NOTE: Forward position; the machine is set to propel forward. Backward position; the machine is set to propel in reverse.

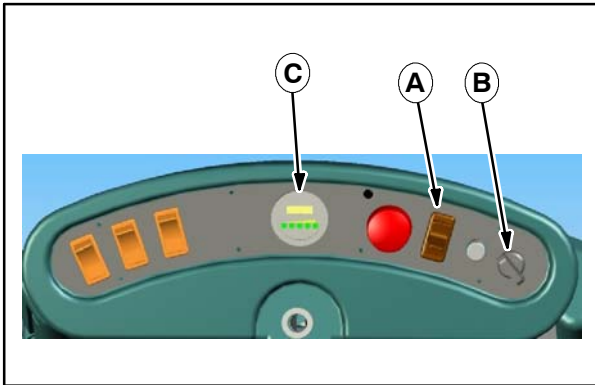

- A. Directional switch
- B. Key switch
- C. Battery condition display

3. Insert the key into the key switch.
4. Turn the key switch.

NOTE: A red LED starts flashing on the battery condition display indicating that the machine is ready for operation. After a few seconds the LED's will change to indicate the battery's charging condition.

5. Press the brake pedal.
6. Release the parking brake.

NOTE: An audible signal will sound when backing the machine.

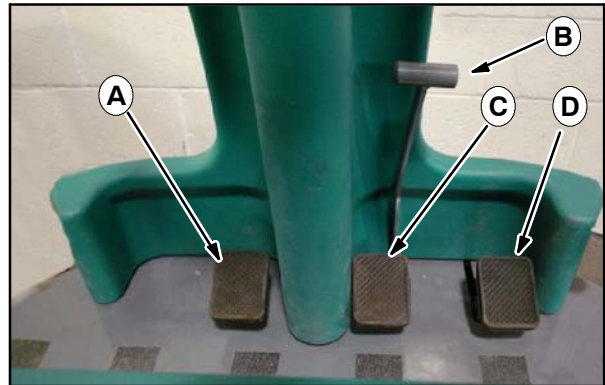

- A. Debris flap
- B. Parking brake
- C. Brake pedal
- D. Accelerator

7. Press the accelerator pedal to adjust the speed of the sweeper.

SWEEPING

SAFETY INFORMATION

Provide adequate ventilation when using the machine in closed rooms or buildings. Do not sweep hazardous materials.

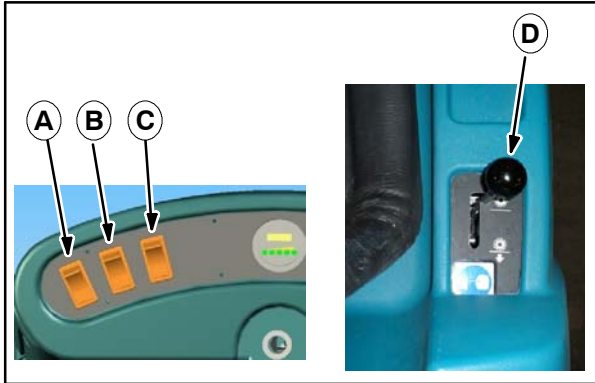

- A. Side brush switch**
- B. Main brush switch**
- C. Vacuum/filter cleaner switch**
- D. Main sweeping brush lever**

OPERATING THE MAIN BRUSH

1. Start the sweeper.
2. Lower the main brush with the main brush lever.
3. Place the main brush switch in the ON position. The indicator lamp on the switch lights up. The main brush begins rotating.
4. Sweep as required.
5. To sweep larger pieces of debris, press the debris flap as needed.

STOPPING THE MAIN BRUSH

1. Place the main brush switch in the OFF position.
2. Raise the main brush with the main brush lever.

OPERATING THE SIDE BRUSH(ES)

1. Start the Sweeper.
2. Place the side brush switch in the ON position. The indicator lamp on the switch lights up. The side brush(es) begins to rotate.
3. Lower the side brush with the side brush lever.

STOPPING SIDE BRUSH OPERATING

1. Place the side brush switch in the OFF position.
2. Raise the side brush with the side brush lever.

OPERATING THE VACUUM

The vacuum prevents dust formation during sweeping operations.

1. Start the sweeper.
2. Place the vacuum/filter cleaner switch in the top vacuum position.

NOTE: The indicator lamp on the switch lights up. The vacuum begins operating.

NOTE: Do not operate vacuum when debris is wet. This will cause damage to the vacuum fan.

Turn off the vacuum operation by placing the switch in the middle OFF position.

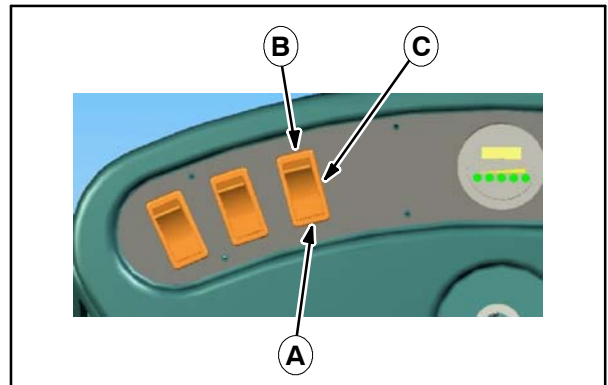

- A. Filter cleaner position**
- B. Vacuum position**
- C. Middle OFF position**

OPERATING THE FILTER CLEANER

The panel filter collects fine dust during sweeping operation. The filter cleaner cleans the dust and prevents the panel filter from being blocked by debris.

1. Place the main brush switch in the OFF position.
2. Place the vacuum/filter cleaner switch in the middle OFF position.
3. Wait until fan stops.
5. Press and hold the switch in the filter cleaner position for about 5–10 seconds.

TURNING OFF THE SWEEPER

1. Press and hold the brake pedal.
2. Lock the brake by pulling the locking lever towards the driver's seat.

NOTE: When the brake is released the brake pedal must remain in pressed position.

3. Switch off all functions.
4. Raise the main brush and side brush(es) with the levers.
5. Turn the key counterclockwise and remove it from the key switch.

FOR SAFETY: Before leaving machine, stop on a level surface, set parking brake, turn off machine and remove key.

EMPTYING THE DEBRIS HOPPER

The debris hopper is where the debris is collected. It is positioned at the back of the sweeper. The debris hopper must be emptied after each use.

REMOVING THE DEBRIS HOPPER

1. Turn the debris hopper locking devices upward.
2. Pull the debris hopper from the sweeper by the handle until the front debris hopper guide rails are free.



WARNING: Brush throws debris. Stop motor before removing hopper.

FOR SAFETY: Before leaving or servicing machine, stop on a level surface, set parking brake, turn off machine and remove key.

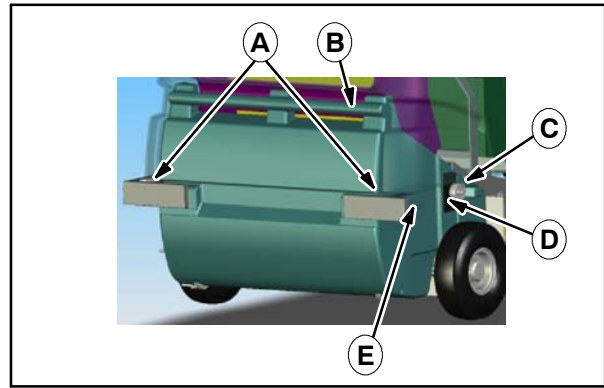

- A. Locking devices**
- B. Handle**
- C. Guide roller**
- D. Guide rail**
- E. Debris hopper guides**

NOTE: At the back of the debris hopper two guiding rollers are installed to make the removal more easy.

3. Lower the debris hopper to the ground.
4. Remove the debris hopper completely from the sweeper.
5. In order to empty the debris hopper use the free hand to take hold of the handle.
6. The debris is discharged through the opening at the front of the hopper.
7. Empty debris into appropriate containers only.
8. Dump heavy loads on floor or use an assistant to help lift.

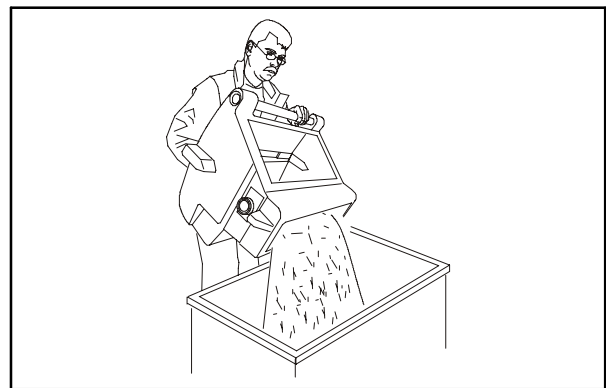

REINSERTING THE DEBRIS HOPPER

1. Position the debris hopper in front of the sweeper opening.
2. Align the debris hopper front guides level with guide rails.
3. Slide the debris hopper into the sweeper.
4. Turn the locking device downward.

REPLACING THE FILTER

1. Open the hood.
2. Lock hood securely using the hood prop.

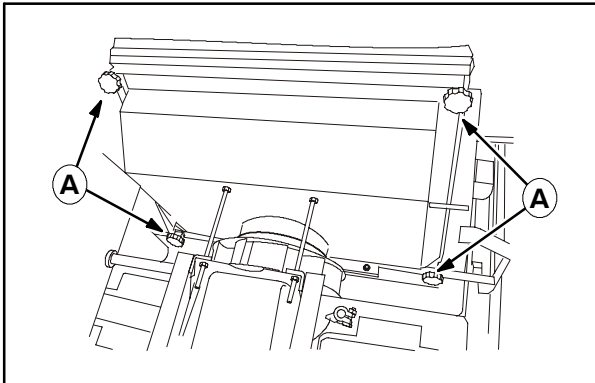

A. Star handles

3. Loosen the top two star handles.
4. Swing up the top angular bracket.
5. Loosen the bottom two star handles.
6. Pull the filter out of the fixture.

POSITIONING THE FILTER

Filter shows the following symbol on the frame.

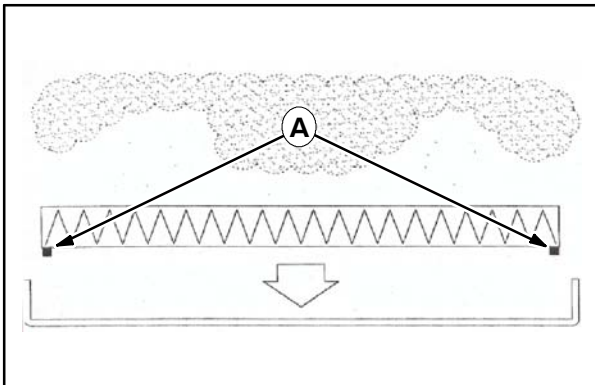

A. Filter seal

Make sure the filter is facing the right direction when installing. The seal filter must show towards the filter housing as shown.

INSTALLING THE FILTER

1. Place the filter into the lower angular bracket.
2. Swing the upper bracket over the filter.
3. Tighten the top star handles slightly.
4. Tighten star handles evenly crosswise so that the filter snugly fits all around the seal.
5. Adjust the bolts and the nuts in a way that, provides the filter with the best possible Sealing inside the casing.

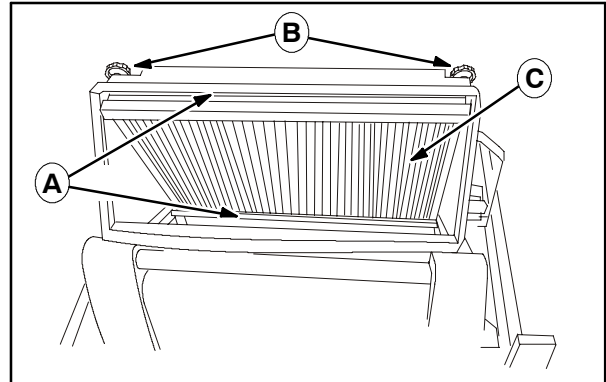

A. Angular brackets

B. Star handle

C. Filter

CLEANING THE SWEEPER

The sweeper is equipped with electrical components.

NOTE: Moisture damages the electronic controls of the machine. Moisture may lead to leak current and short-circuits. Do not use high-pressure cleaning devices.

SIDE BRUSHES

REMOVING THE SIDE BRUSH

FOR SAFETY: Before leaving or servicing machine, stop on a level surface, set parking brake, turn off machine and remove key.

1. Turn off the sweeper.
2. Raise the side brush with the side brush lever.
3. Lift up the side brush motor.

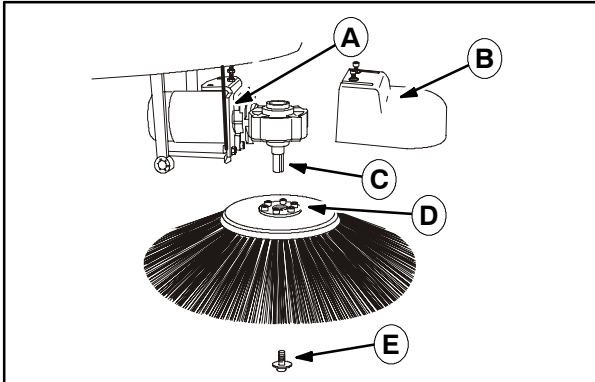

- A. Side brush motor**
- B. Side brush cover**
- C. Shaft with keyway**
- D. Flange base with feather key**
- E. Fastening screw**

4. Loosen the fastening screw at bottom center of the side brush.
5. Pull the side brush down and off.
6. Replace the side brush.

INSTALLING THE SIDE BRUSH

1. Fasten the flange plate to the side brush. The flange plate is equipped with a key. The side brush motor shaft is equipped with a keyway.
2. Turn the side brush until the key fits snugly into the keyway.
3. Slide the shim over the shaft of the side brush motor.
4. Fasten the side brush to the shaft of the side brush motor with the fastening screw.

ADJUSTING THE SIDE BRUSH

Normal wear requires additional adjustment of the side brushes.

1. Turn off the sweeper.
2. Lower the side brush with the side brush lever.
3. Loosen the bolts of the front panel.
4. Remove the front panel.

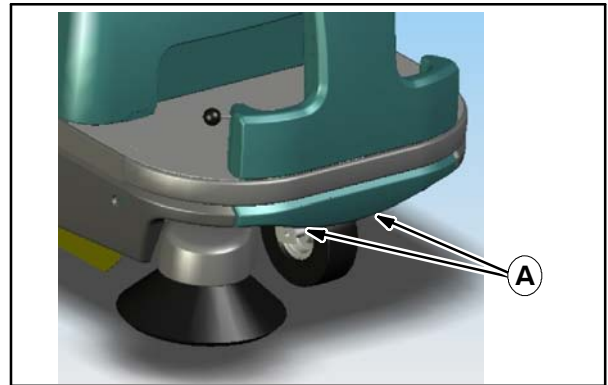

A. Bolts for the front panel

5. Loosen the bolt of the side brush level adjustment.
6. Move the side brush to the desired position.
7. Tighten the bolt of the side brush level adjustment.

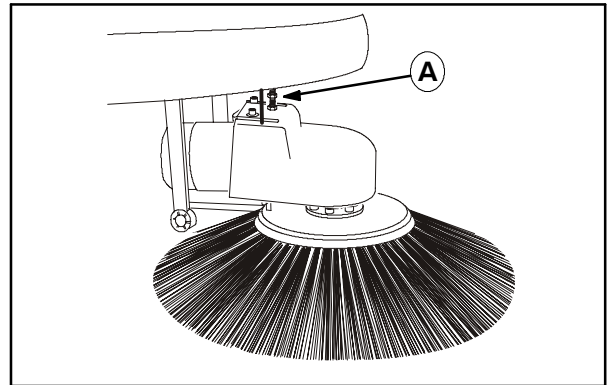

A. Level adjustment bolt for side brush

8. Reinstall the front panel.

MAIN BRUSH

REMOVING THE MAIN BRUSH

FOR SAFETY: Before leaving or servicing machine, stop on a level surface, set parking brake, turn off machine and remove key.

1. Turn off the sweeper.
2. Lower the main brush with the main brush lever.
3. Loosen the bolts of the left side cover.

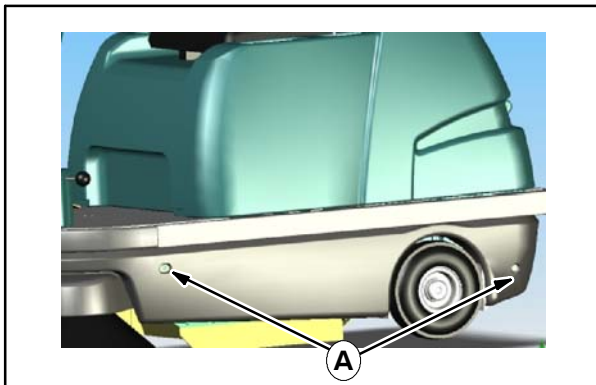

A. Left side cover bolts

4. Loosen the brush plate knob.
5. Remove the main brush plate and open the main brush door.

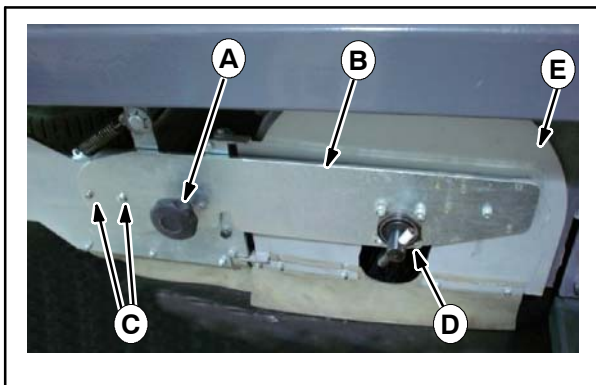

- A. Brush plate knob
- B. Main brush plate
- C. Guide pins
- D. Turning lever
- E. Main brush door

6. Pull the main brush out of the machine and remove any debris, strings, etc., from the brush compartment, the brush, the drive pin (see photo on the right) and the pick-up pin.

INSTALLING THE MAIN BRUSH

1. Push the main brush under the machine.

NOTE: Make sure the brush is facing the proper direction (as shown below).

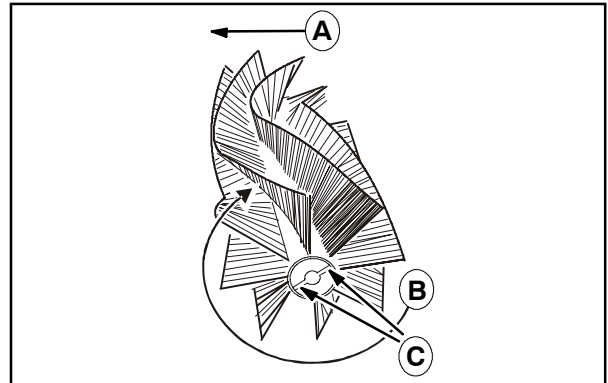

- A. Forward direction
- B. Direction of brush rotation
- C. Brush keyway

2. Turn the main brush until the brush keyway aligns with the drive pin on the far side of the brush compartment (see photo below). Slide the main brush in until it is snug over the the drive pin, then close the main brush door.
3. Holding the main brush plate, rotate the turning lever until the pick-up pin aligns with the brush keyway.

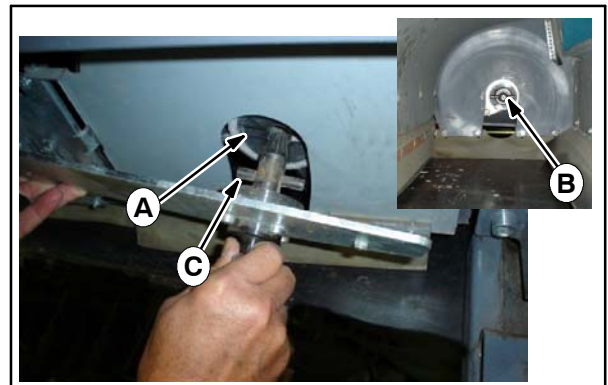

- A. Main brush keyway
- B. Drive pin
- C. Pick-up pin

4. Install the main brush plate, aligning it over the guide pins while pushing the pick-up pin into the main brush.
5. Fasten firmly with the brush plate knob.
6. Reinstall the left side cover.

SETTING THE MAIN BRUSH PATTERN

For best cleaning results and to ensure the highest possible device efficiency, the main brush pattern should be properly set. The sweeping pattern should be set to approximately 30–40 mm on the floor.

CHECKING THE MAIN BRUSH PATTERN

1. Drive the sweeper to an area to be cleaned.
2. Turn the main brush on and lower it to the floor.
3. Allow the main brush to operate for about one or two minutes without moving.
4. Raise the main brush and turn it off.
5. Drive the sweeper forward a few meters.
6. The main brush track visible on the ground is the main brush pattern.

ADJUSTING THE MAIN BRUSH PATTERN

1. Turn off the sweeper.

FOR SAFETY: Before leaving or servicing machine, stop on a level surface, set parking brake, turn off machine and remove key.

2. Lower the main brush.
3. Tilt the main cover forward and prop it open.
4. Adjust brush pattern with the forked lever or cam adjuster as needed.

There are two ways to make adjustments to the main brush pattern.

Fine adjustments can be made by moving the **forked lever** to a different hole. To move the forked lever, open the **quick-release clip**. Then the pin in the lever can be moved to the desired position. Close the clip when finished with the adjustment.

Course adjustments can be made with the **cam adjuster**. Loosen the knob to make an adjustment. Tighten the knob when finished with the adjustment.

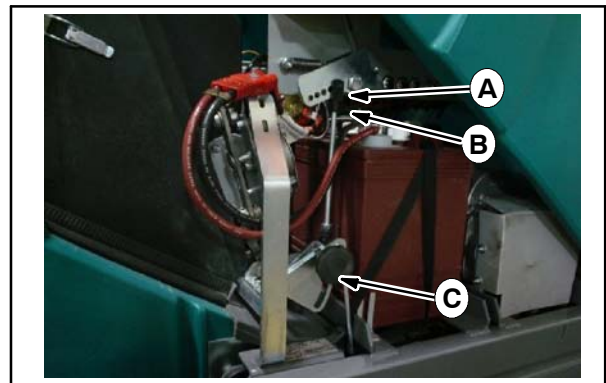

- A. Forked lever adjuster
- B. Quick-release clip
- C. Cam adjuster

BATTERIES

Four batteries supply the sweeper with electrical power. The charging condition of the batteries is indicated by the battery condition display on the control panel.

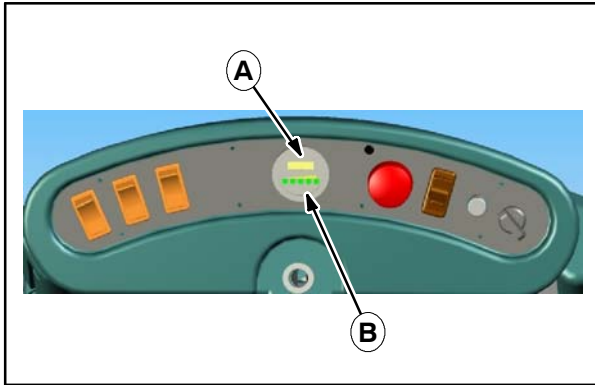

- A. Battery-condition display
- B. LED's

When the sweeper is switched on the red LED flashes five times. Subsequently the electronic system of the sweeper carries out a self-testing operation of the battery charging level. The result of this self-testing is displayed by the 5 LED's.

Information provided by LED indicators on the battery condition display:

lit LED		charging condition of battery			
Red	Yellow	Green	Green	Green	condition fully charged
✱	✱	✱	✱	✱	operating/charging condition uncritical
✱	✱	✱	○	○	operating/only for a short time longer
✱	✱	○	○	○	operating/soon critical
✱	○	○	○	○	operating/critical



WARNING: Batteries emit hydrogen gas. Explosion or fire can result. Keep sparks and open flame away. Keep covers open when charging.

FOR SAFETY: Before leaving or servicing machine, stop on level surface, set parking brake, turn off machine, and remove key.

FOR SAFETY: When maintaining or servicing machine, avoid contact with battery acid.

CHARGING THE BATTERIES

1. Turn off the sweeper.
2. Open the hood.
3. Secure the hood position.
4. Disconnect the power-supply-connector from the Charging connector.
5. Connect the charging device to the charging plug of the sweeper.
6. Check the water level in all the battery cells. If the level is low, add just enough distilled water to cover the battery plates. **DO NOT OVERFILL.** The batteries can overflow during charging due to expansion.

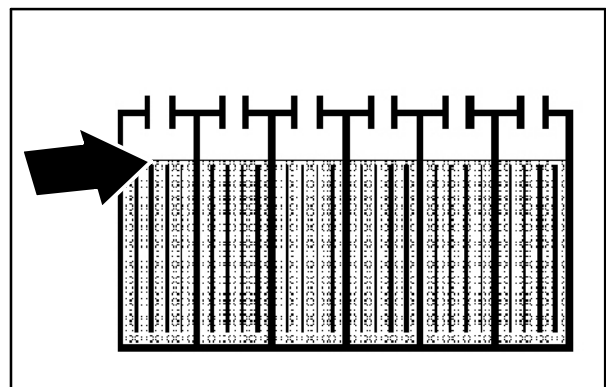

NOTE: Make sure the battery caps are in place while charging.

FOR SAFETY: When maintaining or servicing machine, avoid contact with battery acid.

7. Connect the plug of the charger to a power supply connector.

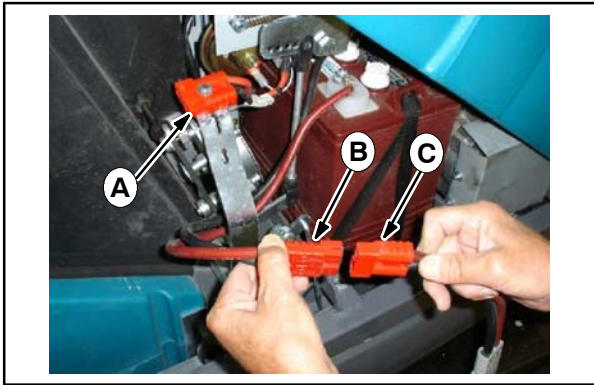

- A. Sweeper connector**
B. Battery connector
C. Charger connector

The charging process lasts for approx. 10 hours when the batteries have been completely depleted (with the device originally provided by the manufacturer). The original charging device of the manufacturer can/should remain connected after charging is completed, because it is equipped with a charge saver allowing it to provide highest possible battery capacities even after long periods of standstill.

Be careful only to use the sweeper if there is enough voltage left in the batteries. The machine automatically switches itself off, if the batteries are discharged to such a degree that damages may occur (excessive discharge protection).

In this case: Switch off all functions and let the machine stand for about one or two minutes. Switch on the machine again and drive to the charging device (without sweeping operation!) Charge batteries immediately to avoid possible damages.

BRAKE

The brake (drum brake) acts on the front wheel and is controlled via the brake cable by the brake pedal.

The brake adjustment is situated on the right side of the front wheel facing in driving direction.

ADJUSTING THE BRAKE

FOR SAFETY: Before leaving or servicing machine, stop on a level surface, set parking brake, turn off machine and remove key.

1. Hold the adjustment nut of the cable in place with a wrench.
2. Loosen the back nut of the adjustment nut.

3. Push the brake lever upward until the brake lever is fully engaged.
4. Hold the brake lever in this position.
5. Tighten the back nut of the adjustment nut.
6. Now conduct a brake-test.

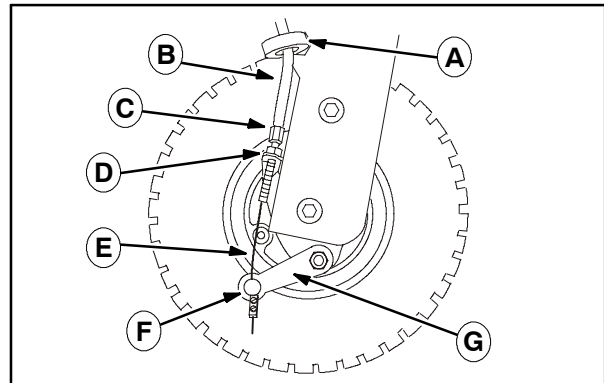

- A. Wire guide**
B. Brake conduit
C. Adjustment nut
D. Back nut
E. Brake cable
F. Brake cable lock
G. Brake lever

BRAKE CHECK

FREE MOVEMENT OF FRONT WHEEL

You must be able to move the sweeper by pushing when the brake is released. The front wheel must not be blocked. Brakes that are set too tightly damage the brake drum.

CORRECT OPERATING OF BRAKE

Carefully drive a few meters at moderate speed. Press the brake pedal. The sweeper must stop. If the brake check should not render a satisfying result the setting procedure must be repeated.

FURTHER SETTING POSSIBILITY

The cable no longer allows tightening in the way described above any longer.

1. Loosen the cable lock.
2. Lift the brake lever up until it is fully engaged.
3. Hold the brake lever in the "up" position.
4. Pull the brake cable down and push the brake lever upward.
5. Fasten the brake cable lock.
6. Repeat the brake check.

CIRCUIT BREAKERS

The resettable circuit breakers are positioned on the right side under the hood, facing in driving direction.

FOR SAFETY: Before leaving or servicing machine, stop on a level surface, set parking brake, turn off machine and remove key.

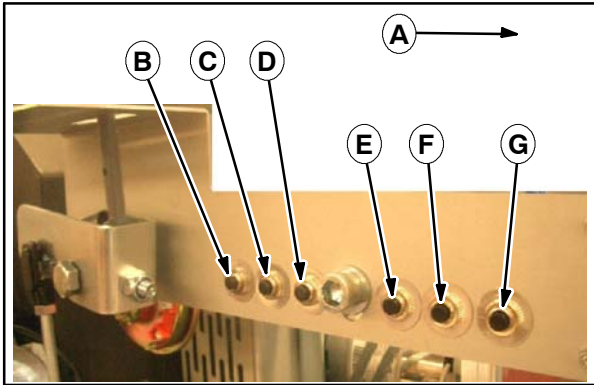

- A. Forward motion
- B. CB1 Vacuum fan
- C. CB2 Main brush
- D. CB3 Side brush
- E. CB4 Horn, buzzer, beacon
- F. CB5 Traction
- G. CB7 Battery monitor/Relays

To reset a circuit breaker simply press the black part of the circuit breaker back into the snap-in position. Make sure that the cause for the circuit breakers to be disengaged will be identified and fixed by a qualified person.

STEERING

The steering transferal to the front wheel is managed by a chain and two chain sprockets. Grease the chain sprockets at regular intervals. See maintenance chart.

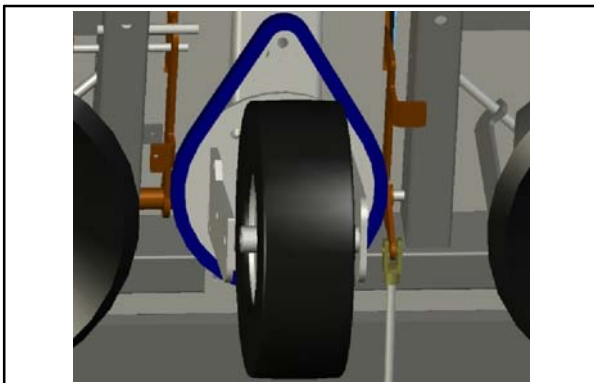

BRUSH DRIVE

The brush drive is located on the right side of the sweeper facing the driving direction. The main brush is driven by an electric motor via a chain. The chain is deflected by a sprocket and guided over the sprockets of the brush drive. A spring biased chain tensioner keeps the chain tight.

Grease the sprockets at regular intervals. See maintenance chart. To grease the sprockets, open the hood and remove the side trim panel.

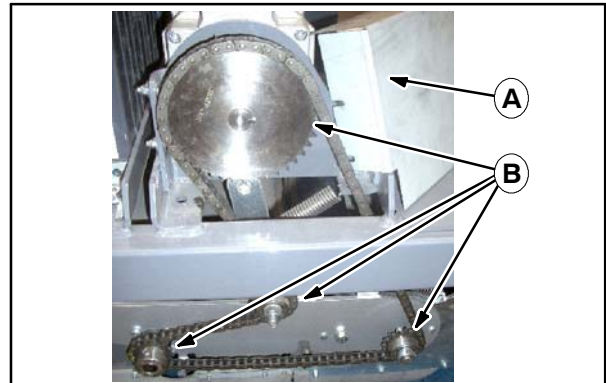

- A. Main brush sprocket guard
- B. Sprockets

TRANSPORTING THE MACHINE

For the safe transport of the sweeper in a crate or on a pallet: tie down the machine by fixing two straps as shown below.

The **front strap** should be fixed across the frame along the foot-rest. The **rear strap** should be fixed across the frame along the area below the vacuum fan. Protect the paint of the frame by using a soft cloth or cardboard-box.

FOR SAFETY: make sure to use straps that withstand an increased load due to vibrations of the machine during transport.

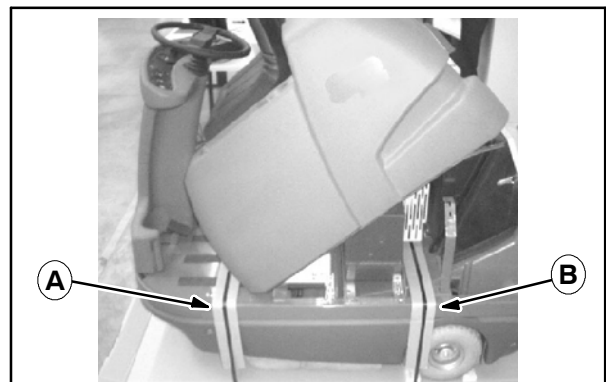

- A. Front strap
- B. Rear strap

MAINTENANCE CHART

DAILY MAINTENANCE

- Charge battery.
- Check battery acid level, if required add distilled water.
- Check if machine is damaged or impaired in any way.
- Check condition of dust filter and clean if necessary.
- Empty debris hopper.

AFTER 50 HOURS OF OPERATION

- Check if battery leaks acid.
- Clean and grease battery poles.
- Check the main brush for wear or damage. Clean or replace if required.
- Check main brush pattern, readjust if required.
- Check if side brush adjustment is worn, if required readjust or replace.
- Search brush tunnel for jammed particles and seized up dirt that may narrow the brush tunnel and obstruct free brush movement.

AFTER 100 HOURS OF OPERATION

- Check battery cable isolation, replace cables if required.
- Check if battery cable connections are tight.
- Grease steering chain.
- Grease brush drive chain.
- Clean dust filter, replace if necessary.
- Search vacuum for obstacles, clean if necessary.
- Conduct trial run to check all operating elements.
- Check if brush drive chain is stretched or loosened.
- Check all bearings for wear.
- Check if seals are damaged or dislocated.

AFTER 200 HOURS OF OPERATION

- Check operation of electric motors.
- Check if carbon brushes are worn, replace if required.
- Check steering clearance, tighten chain if required.
- Check all electrical system components for dirt. Clean if required.

MACHINE TROUBLESHOOTING

Problem	Cause	Remedy
No operating display at control panel	EMERGENCY OFF not switched on	Turn EMERGENCY OFF switch counter clockwise
	Key switch not switched on	Turn key switch and check correct load
	Fault in electrical wiring	Check plug connections
	Battery charge empty	Charge battery
No operation of propelling drive inspite of display at control panel	Accelerator was depressed at start	Release accelerator and re-start
	Circuit breaker 5 or 7 or fuse 6 defective	Reset circuit breaker / replace fuse
	Fault in electrical connections	Check plug connections and compare
	Problems in electronic control	Have control checked by authorized person
No operation of one of the electrical components	Circuit breaker inactive	Reset circuit breaker
	Fault in electric connections	Check plug connections of corresponding system component: check especially sweeping brush whether obstructed by bands, cables, strings
Sweeping result unsatisfactory	Side brush(es) or main sweeping brush not lowered	Lower
	Side brush(es) or main brush worn	Adjust
	Brush tunnel clogged by dirt	Check if brush trim panel is impaired by jammed debris
	Main brush does not operate	Install brush correctly Check to see if the motor rotates
	Dust formation too great	If required switch off side brushes
	Vacuum fan does not operate	Check if electrically defective
	Filter excessively dirty	Clean filter
	Filter not correctly fitted	Check for tight fit
Circuit breaker of the sweeping brush does not remain set	Main brush is jammed by dirt, cords, strings etc.	Dismount and clean brush
Circuit breaker of the side brushes does not remain set	Side brushes are jammed by dirt, cords, strings or debris	Check side brushes and remove obstacles
Circuit breaker of vacuum Does not remain set	Vacuum fan does not move freely	Check fan and remove any obstruction
Circuit breaker of propelling drive does not remain set	Drive wheels obstructed	Jack up the sweeper check differential operation of wheels and free running

SPECIFICATIONS

DIMENSIONS AND WEIGHT

Item	Measure
Length	1420 mm
Width	900 mm
Height at steering wheel	1140 mm
Weight: without batteries	210 Kg
Weight: with batteries	340 Kg
Sweeping width without side brush	700 mm
Sweeping width with one side brush	900 mm
Sweeping width with two side brushed	1100 mm
Debris hopper volume	90 Ltrs.
Turning Radius	1 m
Climbing capacity	Up to 20%
Speed	0-6 km/h
Filter Area	4 m ²
Air volume of the dust suction	900m ³
Supporting frames	Steel construction, powder coated
Trim panel parts	Impact resistant plastic
Vibration level does not exceed	2.5 m/s ²
Sound level maximum	70 dB (A)

ELECTRICAL INSTALLATION

Circuit Breakers	Circuit	Measure
CB1	Vacuum/filter cleaner	20
CB2	Mainbrush	25 A
CB3	Sidebrush(es)	10 A (20 A)
CB4	Horn,busser, beacon	20A
CB5	Propel-system	45 A
CB7	Battery-monitor, relais	20 A
Fuse		
CB6	Controller Power Supply	1A

ELECTRIC DRIVES

Motor	Measure
Propelling drive	differential geared motor 24V, 130 rpm, 400 W
Side brushes	geared motor 24V, 90 rpm, 90 W
Sweeping brush	24V, 220 rpm, 400 W
Suction	24V, 3000 rpm, 300 W

TIRES

Location	Type	Size
Front (1)	Solid	260 mm x 85 mm
Back (2)	Pneumatic (air pressure 5,5 bar)	260 mm x 85 mm

BRAKES

Brake	Location
Drum brake	On front wheel
Parking brake	On front wheel

