



Clemas & Co Ltd

Industrial Cleaning Equipment
Sales - Hire - Service

GANSOW SCRUBBER DRIER



SERVICE MANUAL

FOR 31 B 50

Clemas & Co. Unit 5 Ashchurch Business Centre, Alexandra Way,
Tewkesbury,
Gloucestershire, GL20 8NB.

Tel: 01684 850777

Fax: 01684 850707

Email: info@clemas.co.uk

Web: www.clemas.co.uk

INDEX:

1. IMPORTANT WARNINGS.....	3
2. INSTRUCTIONS BEFORE OPERATING.....	5
3. PRACTICAL GUIDE FOR THE OPERATOR.....	6
4. INSTRUCTIONS.....	8
5. TROUBLESHOOTING.....	12
6. CLEANING AND MAINTENANCE.....	15
7. OPTIONAL ACCESSORIES.....	16
8. CE CONFORMITY DECLARATION.....	17
9. TECHNICAL SPECIFICATION.....	22
SPECIAL INFORMATION FOR	
10. USING THE BATTERIES AND CHARGER.....	23
CONTROL AND MAINTENANCE	
11. OPERATIONS.....	27

1. IMPORTANT WARNINGS:

- 1.1. **IMPORTANT!** This appliance is not suitable for removing dusts hazardous to health.
- 1.2. **IMPORTANT!** This appliance is not suitable for washing carpet or textile floors or wood floors not treated with non-absorbent resin.
- 1.3. This appliance is not approved for use on public roads or highways.
- 1.4. This appliance may only be used by personnel fully trained in its correct and appropriate use.
- 1.5. In order to prevent unauthorised use of the machine always remove the key from the key switch before leaving the appliance unattended.
- 1.6. Lower the brushes before leaving the machine unattended to prevent accidental movement.
- 1.7. When using the machine the operator should take care not to endanger any third persons, particularly children.
- 1.8. The appliance may not be used on slopes of greater than 2%.
- 1.9. We expressly draw your attention to the fact that original parts and accessories not supplied directly by Gansow have not been tested or authorised by Gansow.
The installation and/or use of such items may therefore adversely affect the efficiency and characteristics of your floor cleaning machine, jeopardising its active and passive safety.
The manufacturer declines all liability for damage occurring as a result of the use of non-original parts or accessories.
- 1.10. Before any cleaning or servicing work is carried out on the machine, the following precautions must be taken:

- unplug the plug from the charger from the charger socket; - remove the key from the control panel.

ATTENTION !

Before changing the main fuse, disconnect the battery cables from the respective terminals (danger of short circuit).

- 1.11. Under no circumstances may the charger leads (connecting the charger to the machine) supplied be modified.
- 1.12. All electrical functions of the machine are interrupted immediately as soon as the plug is plugged into the charger socket.
- 1.13. This appliance may be used with the brushes provided by the producer only.

ATTENTION !

The safety of the appliance will be jeopardised by the use of other brushes.

- 1.14. ***IMPORTANT - battery gas is highly explosive;** -
avoid sparks or open flames close to the batteries!
To avoid the build-up of gas inside the machine, the tank and tank lid must remain in the raised position throughout charging. The caps of all battery cells must also be unscrewed and/or removed (not necessary in the case of gel batteries).
- 1.15. ***IMPORTANT - battery acid is corrosive!**
When topping up with distilled water make sure the level of liquid is the same in all the battery cells. Dry cells shorten battery life and may cause irreparable damage to the entire battery (not relevant to gel batteries).
- 1.16. **IMPORTANT!** Rooms where batteries are being charged should always be well ventilated.

** Not relevant to maintenance free gel batteries*

2. INSTRUCTIONS BEFORE OPERATING:

- 2.1. Before operating a battery-powered machine, please read all the following instructions and the instructions for use of the charger (if purchased).
- 2.2. Note that the batteries deliver maximum power only after eight to ten charging cycles. During this period, the machine should not therefore be used for excessively heavy cleaning.
- 2.3. To provide your battery with even greater protection, the machine is equipped with a charge indicator and hour counter.

By means of variously coloured LEDs (seven yellow and one red), this provides a constant indication of the charge and automatically shuts the brush motors down when the charge drops below the safety level.

The **LEDs** indicate the following stages:

YELLOW ON: batteries within the charge limit

YELLOW FLASHING 15 seconds of running time remain before the brush motors shut down.

RED ON: the battery is flat and the brushes are blocked. You should immediately go to the charging area to avoid damaging the batteries.

The transition of one LED to another with a delay of just 15 seconds ensures a prompt response in the event of flat batteries to avoid discharging them further and therefore irreparably reducing their working life.

- 2.4. **IMPORTANT!** The machine must not under any circumstances be started up with the front and top lids raised.

3. PRACTICAL GUIDE FOR THE OPERATOR:

3.1. *IMPORTANT - Seal the battery cells by screwing on the caps.

** Not relevant to maintenance free gel batteries*

3.2. After turning the charger off, unplug the connection lead from the charger from the battery socket to power the machine.

3.3. Lift the top lid and use a hose or bucket to fill the clean water tank (on the left) with cold water up to a maximum of 3 cm from the top of the tank (the water should preferably be cold and in any case never hotter than 60°C).

IMPORTANT! Use low foam detergent as excessive foam could jeopardise the efficiency and function of the machine.

Close the top lid, lifting slightly on the hinge side to make sure it fits perfectly to the tank.

IMPORTANT! If the lid does not fit perfectly, there would be no vacuum at the squeegee and therefore no flow-back of liquid to the collection tank (on the right). If necessary, repeat the operation correctly.

Avoid resting heavy objects on the lid as this could warp it and prevent it from fitting perfectly to the tank.

3.4. Make sure the cap of the dirty water tank (on the right) drain hose is correctly in place. Perfect closure of the cap is essential to obtain a vacuum in the collection tank and therefore maximum suction power.

3.5. Turn the key switch clockwise to start the machine.

- 3.6. Light pressure and a slight sideways movement of the pedal release the brushes which are lowered in contact with the ground.
- 3.7. To activate brush rotation, press the corresponding button on the left side of the control panel.

MACHINES WITH DIAPHRAGM: *Pressing this button opens the water solenoid valve and turns the water pump on.*

Turn the knob on the control panel clockwise to adjust the quantity of water to the brushes (from 0 to 7 litres).

MACHINES WITHOUT DIAPHRAGM: *Pressing this button opens the water solenoid valve.*

To adjust the quantity of water to the brush in accordance with the dirt to be removed (more dirt=more solution), use the red lever at the bottom on the operator's right. When the lever is horizontal, the cock is fully open, when vertical it is completely closed.

- 3.8. Lower the squeegee to the ground, using the control lever in front of the operator under the handle.
- 3.9. Turn on suction to convey the dirty water to the collection tank, using the button marked with a fan on the right of the control panel.

4. INSTRUCTIONS:

4.1. SERIES "B" MODELS WITHOUT DRIVE:

The appliance is equipped with a patented drive system - as the brush rotates in contact with the ground, it draws the whole machine along at the correct working speed.

By pushing slightly, the drive speed can be increased as required. Holding it back slows it down.

SERIES "BF" MODELS WITH DRIVE:

Push the drive lever gradually forwards to advance the machine at the required speed. The maximum possible speed is 5.5 km/h.

On curves, adjust speed by moving the drive lever backwards. When the lever is released completely, the drive motor stops automatically.

ATTENTION!

The drive unit is fitted with a crush prevention device consisting of a square red button at the centre of the handle which changes the direction of movement if touched while the appliance is in reverse. This prevents the operator being crushed in the event of incorrect manoeuvres.

4.2. Clean in parallel strips overlapping by 3 to 4 cm.

Rollers on the ends of the squeegee act as bumpers and also enable you to clean at a tangent to the edges. The extreme manoeuvrability of the squeegee which can be swung freely and widely to both sides enables you to clean around any obstacle. The squeegee then returns to the central position when the obstacle or curve has been passed. When consigning the machine or during a demonstration, our service technician can advise you on the best way of cleaning your own particular floor surface.

4.3. By means of a vacuum created inside the collection tank, the used water and the dirt are completely absorbed and conveyed to the dirty water tank.

To prevent dirty water or foam damaging the vacuum motor, the collection tank is protected by two sensors (*electrodes*) which shut the machine down when the tank is full (*they also detect the level of any foam present*).

4.4. After finishing the work or when the solution in the tank is used up (indicated with a red flashing light on the switch board), stop brush rotation by pressing the corresponding button. This also stops the flow of water. Raise the head using the pedal.

4.5. To collect the remaining dirt, continue for a further 3-4 metres with suction activated and the squeegee lowered, than turn both functions off by pressing the suction button and raising the squeegee lever. This empties all water left in the circuit into the collection tank.

IMPORTANT !

After you have finished cleaning, you are recommended to raise the tank lid and turn the suction motor on again for a few minutes. The dry air sucked in will evaporate any remaining moisture, extending the working life of the motor.

4.6. Empty the collection tank into a container or drain using the black drain hose and proceeding as follows:

- detach the hose from the control panel;
- **keeping the hose raised above the level of the tank at all times**, remove the cap;
- lower the hose gradually towards the container.

4.7. **IMPORTANT!** After each cleaning session, you are recommended to drain the dirty water and rinse the tank to avoid unpleasant smells or the formation of harmful germs. **To make this operation faster,**

simpler and more effective, the appliance is fitted with an exclusive system:

- the tank tilts backwards, after raising the lid, lift the tank until it rests on the chassis (empty before tilting);
- after removing the cap, lower the drain hose to allow the water to run off rapidly;
- wash the collection tank with running water;
- leave the tank tilted until the next time you use the machine.

The appliance has been designed to facilitate thorough maintenance. A little attention improves the efficiency of your appliance and extends the already long working life.

4.8. When parking the machine, you are recommended to lower the brush head to anchor it to the ground.

4.9. The machine has a rapid brush replacement system:

- 1- *turn the key to the off position (anticlockwise as far as it will go),*
- 2- use the pedal to lift the brush head,
- 3- *hold the brush with both hands and turn it sharply in the normal direction of rotation. In the case of heads with two motors, the direction of rotation is always towards the centre of the head. Hold the bayonet coupling firmly in position and release the brush.*
- 4- remove the brush and position the replacement in the centre of the housing, precisely under the bayonet coupling,
- 5- *use the pedal to raise the brush head,*
- 6- switch the appliance on and activate brush rotation for a few moments, then turn off again,
- 7- *finally, raise the brush head and make sure the brush is correctly fitted. If necessary, repeat operations 1 to 6.*

4.10. The key switch should be turned off before recharging the batteries.

4.11. In order to avoid any build-up of gas inside the machine, the tank (previously emptied) covering the batteries must be raised and remain in that position throughout charging. Similarly, the caps of all battery cells must also be unscrewed and/or removed (not necessary in the case of maintenance-free gel batteries).

PRECAUTIONS

Battery gas is highly explosive. Avoid sparks and open flames near the batteries.

When topping up with distilled water make sure the level of liquid is the

same in all the battery cells. Dry cells shorten battery life and may cause irreparable damage to the entire battery (*not relevant to maintenance-free gel batteries*).

ATTENTION!

If the battery is damaged, the acid is highly corrosive!

4.12. IMPORTANT! Rooms where batteries are being charged should always be well ventilated.

Before using battery-powered models, read carefully the instructions on use and maintenance of the machine, batteries and charger; procedures and precautions to be observed while charging batteries and connecting the charger and inspection and maintenance of batteries and maintenance schedules.

5. TROUBLESHOOTING:

5.1. *No water is delivered, check that:*

- the brush is moving,
- if necessary, activate the brush by using the button on the left of the control panel,
- there is water in the tank and the level is above the filter (the red LED on the switch board is flashing),
- if necessary, top up and add detergent,
- the clean water filter is not clogged,
- if necessary, remove and clean with air from the outside inwards,
- the water solenoid valve is operating correctly,
- if necessary, remove and clean,
- the water cock is open (lever horizontal = fully open, lever vertical = fully closed),
- the knob on the control panel (diaphragm machines only) is not on zero.

5.2. *The water flow does not stop:*

- close the water cock, then remove the solenoid valve and thoroughly clean the inside, including the closure spring housing, - open the cock again and check it works,
- replace the valve if necessary.

5.3. *The suction motor does not start:*

- reset by using the key switch to turn the appliance off then on again,
- clean the collection tank around the sensor electrodes and the electrodes themselves.

ATTENTION!

Do not move the electrodes from their original position. Make sure they are not already out of position. By modifying the distance between them, or between the electrodes and the side of the tank, the power cut-off mechanism may be activated by mistake. Contact the

Gansow Distributor Technical Assistance Service if necessary.

- check the main fuse.
- check the charge of the batteries and if necessary, charge.

5.4. *Water is not sucked up, although the motor is operating;*

- make sure the cap is correctly in place on the drain hose.
- make sure the suction hose between the squeegee and the dirty water tank is not blocked. If necessary unblock and fix the hose well to both connecting pieces.
- make sure the top lid is correctly in place on the tank, raise and lower as described in point 3.3,
- check the batteries are not flat.

5.5. *The squeegee leaves wet marks or stripes:*

- clean the blades of the squeegee and remove any trapped grit or paper,
- check the wear of the squeegee blades and if necessary, turn or replace,
- PARABOLIC SQUEEGEE: make sure that when moving forwards with suction on, the squeegee is perfectly horizontal. If necessary, adjust the central nuts.
- carry out the checks described in point 5.4.

IMPORTANT !

When dealing with large amounts of fluff, this may accumulate under the rear squeegee blade causing leakage and therefore preventing perfect drying. If this occurs, the squeegee should be raised while at the same time moving the machine backwards to pick up the dirt left on the ground, proceeding in a diagonal direction.

5.6. *The squeegee sticks to the floor due to strong suction:*

- check the state of the front blade and in particular the inlet slits. If obstructed or worn, clean or enlarge them slightly, or cut one to three additional slits until the squeegee functions correctly,

- turn round or replace excessively worn squeegee blades. They can be reversed to extend the working life,
- **STRAIGHT SQUEEGEE:** adjust pressure on the ground using the screw on the mobile support, tightening lightens the pressure, unscrewing increases pressure.
- **PARABOLIC SQUEEGEE:** adjust pressure on the ground by tightening the adjustment nuts above the levelling wheels on the back of the squeegee.

5.7. *The brush motor shuts down:*

- the automatic battery protection device has tripped. Stop working and recharge the batteries immediately.

5.8. *The dirty water does not drain out through the hose:*

- make sure the tank is not blocked near the drain outlet.
- remove any blockages in the drain hose itself.

5.9. *The machine leaves a smeary mark:*

- no water flow,
- *no solution in the tank (fill the tank), or solution tank filter dirty (clean filter),*
- check the brush feed pipe which could be blocked, - *open the water cock if closed.*
- carry out the additional checks described in point 5.1.

5.10. *The machine does not move forward or moves forward too slowly (BF SERIES MODELS WITH DRIVE ONLY)*

- check and remove any oxidation on the battery terminals, then tighten,
- the squeegee is stuck to the ground by excessive suction. See point 5.6.
- the batteries are flat, stop work and recharge.

6. SERVICE AND MAINTENANCE:

- 6.1.** Before any servicing or maintenance work is carried out on the machine and before any parts are replaced:
- drain both tanks completely,
 - unplug the plug from the charger from the charger socket,
 - turn off the key switch.
- 6.2.** The electrodes in the dirty water tank should always be kept clean and in their original position. By modifying the distance between them, or between the electrodes and the tank, the power cut-off mechanism may not activate correctly.
- 6.3.** Clean the dirty water tank thoroughly and regularly to prevent the formation of unpleasant odours and bacteria. Tilt the tank to facilitate cleaning.
- 6.4.** The tank lid should always be left open between cleaning sessions to enable the internal surface to dry out. Never place heavy objects on the top lid as this could warp it.
- 6.5.** After each cleaning session, clean the outside of the machine to remove any chemical residues which could accelerate wear and affect the appearance of the materials.
- 6.6.** The filter in the clean water tank should be cleaned regularly twice a week.
- 6.7.** Check the state of the squeegee blades regularly and if necessary turn them over or replace them. See also sections 5.5. and 5.6.

- 6.8. Perform battery maintenance regularly to maintain their efficiency and extend their working life. They are expensive and should be kept in good condition.
- 6.9. The outlet slits on the suction motor should be checked and cleaned regularly, especially where there is a considerable amount of fluff in the atmosphere.
- 6.10. A general control by authorised Gansow personnel is recommended at least once every six months.

7. OPTIONAL ACCESSORIES:

7.1. Depending on the type of floor and dirt, you may want to use brushes other than those supplied as standard.

The following are available from your Gansow Distributor:

- Black soft and PES brushes for delicate floors (gyms, sealed wood, etc);
- in polycarbonate of various hardnesses for a more energetic and deep treatment.

7.2. As an alternative to the brushes, you can use a pad, available in three versions with different colours:

- **black** = abrasive
- **red/green/purple** = medium hard
- **brown/yellow/white** = soft.

The brush does not need to be removed to use the pad, which can be fitted directly to the brush itself. Alternatively, a special pad holder can be provided.

8. TECHNICAL SPECIFICATION:

		31 B 46/50	41 B/BF 53/57	61 B/BF 53/57
Cleaning width	mm	460/500	530/570	530/570
Squeegee width	mm	870	870	870
Capacity per hour theor.	m²/h	1840	2120/2930	2120/2930
Maximum speed	km/h	4	4/5,5	4/5,5
Number of brushes	no.	1	1	1
Brush diameter	mm	460	533	533
Max. brush pressure	kg	24	31.5	31.5
Pressure of brush head on the ground	g/cm²	110	109	109
Brush rotation speed	rpm	180	200	200
Brush motor power	W	600	650	650
Drive	-	Mechanical	B : MECHANICAL BF : ELECTRONIC	B : MECHANICAL BF : ELECTRONIC
Nominal drive motor power	W	/	B : / BF : 200	B : / BF : 200
Suction motor power	W	350	410	550
Sound pressure	dB(A)	83	83	83
Solution tank	l	26	40	62
Collection tank	l	26	40	62
Diaphragm	/	-	-	Yes
Drive wheel diameter	mm	160	230	230
Pivoting wheel diameter	mm	125	125	125
Net weight without batteries	kg	100	B : 129 BF : 142	B : 135 BF : 148
Number of batteries	no.	2	2	2

Voltage of batteries in series	V	24	24	24
Machine size	cm X/Y/Z	124x51x95	128,5x60,5x108,5 143x60,5x108,5	128,5x60,5x113 143x60,5x113
Total oscillation value	m/s²	<2,5	<2,5	<2,5

TECHNICAL SPECIFICATION:

		61 B/BF 65/68	71 BF 70/72	71 BF 85
Cleaning width	mm	650/680	700/720	850
Squeegee width	mm	1000	1000	1150
Capacity per hour theor.	m²/h	2120/2930	3850	4675
Maximum speed	km/h	4/5,5	5,5	5,5
Number of brushes	no.	2	2	2
Brush diameter	mm	345	370	430
Max. brush pressure	kg	31,5	40	45
Pressure of brush head on the ground	g/cm²	125	156	135
Brush rotation speed	rpm	180	180	180
Brush motor power	W	250	400	400
Drive	-	B : MECHANICAL BF : ELECTRONIC	ELECTRONIC	ELECTRONIC
Nominal drive motor power	W	B : / BF : 200	400	400
Suction motor power	W	550	550	550
Sound pressure	dB(A)	83	82	82
Solution tank	l	62	70	70
Collection tank	l	62	70	70
Diaphragm	/	Yes	-	-
Drive wheel diameter	mm	230	230	230
Pivoting wheel diameter	mm	125	160	160
Net weight without batteries	kg	B : 137 BF : 150	185	187
Number of batteries	no.	2	4	4
Voltage of batteries in series	V	24	24	24

TECHNICAL SPECIFICATION:

Machine size	cm X/Y/Z	124x69x113 139x69x113	163x76x111	167x86x111
Total oscillation value	m/s²	<2,5	<2,5	<2,5

		91 BF 70/72	91 BF 85	101 BF 70/72
Cleaning width	mm	700/720	850	700/720
Squeegee width	mm	1000	1150	1000
Capacity per hour theor.	m²/h	3850	4675	3850
Maximum speed	km/h	5,5	5,5	5,5
Number of brushes	no.	2	2	2
Brush diameter	mm	370	430	370
Max. brush pressure	kg	40	45	40
Pressure of brush head on the ground	g/cm²	156	135	156
Brush rotation speed	rpm	180	180	180

TECHNICAL SPECIFICATION:

Brush motor power	W	400	400	400
Drive	-	ELECTRONIC	ELECTRONIC	ELECTRONIC
Nominal drive motor power	W	400	400	400
Suction motor power	W	550	550	550
Sound pressure	dB(A)	82	82	85
Solution tank	l	90	90	100
Collection tank	l	90	90	100
Diaphragm	/	Yes	Yes	Yes
Drive wheel diameter	mm	230	230	230
Pivoting wheel diameter	mm	125	125	160
Net weight without batteries	kg	169	171	179
Number of batteries	no.	4	4	4
Voltage of batteries in series	V	24	24	24
Machine size	cm X/Y/Z	139x76x113	139x86x113	163x76x115,5
Total oscillation value	m/s²	<2,5	<2,5	<2,5

		101 BF 85	121 BF 70/72	121 BF 85
--	--	------------------	---------------------	------------------

TECHNICAL SPECIFICATION:

Cleaning width	mm	850	700/720	850
Squeegee width	mm	1150	1000	1150
Capacity per hour theor.	m²/h	4675	3850	4675
Maximum speed	km/h	5,5	5,5	5,5
Number of brushes	no.	2	2	2
Brush diameter	mm	430	370	430
Max. brush pressure	kg	45	40	45
Pressure of brush head on the ground	g/cm²	135	156	135
Brush rotation speed	rpm	180	180	180
Brush motor power	W	400	400	400
Drive	-	ELECTRONIC	ELECTRONIC	ELECTRONIC
Nominal drive motor power	W	400	400	400
Suction motor power	W	550	550	550
Sound pressure	dB(A)	85	82	82
Solution tank	l	100	120	120
Collection tank	l	100	120	120
Diaphragm	/	Yes	Yes	Yes
Drive wheel diameter	mm	230	230	230
Pivoting wheel diameter	mm	160	160	160
Net weight without batteries	kg	181	194	196

TECHNICAL SPECIFICATION:

Number of batteries	no.	4	4	4
Voltage of batteries in series	V	24	24	24
Machine size	cm X/Y/Z	167x86x115,5	163x76x115,5	167x86x115,5
Total oscillation value	m/s²	<2,5	<2,5	<2,5

		101 BF 70/72 S	101 BF 85 S	131 BF 100 S
Cleaning width	mm	700/720	850	1000
Squeegee width	mm	1000	1150	1150
Capacity per hour theor.	m²/h	3850	4675	5500
Maximum speed	km/h	5,5	5,5	5,5
Number of brushes	no.	2	2	2
Brush diameter	mm	370	430	370
Max. brush pressure	kg	40	45	54
Pressure of brush head on the ground	g/cm²	270	225	240
Brush rotation speed	rpm	180	180	180
Brush motor power	W	600	600	600
Drive	-	ELECTRONIC	ELECTRONIC	ELECTRONIC

TECHNICAL SPECIFICATION:

Nominal drive motor power	W	850	850	1100
Suction motor power	W	550	550	660
Sound pressure	dB(A)	83	83	85
Solution tank	l	100	100	130
Collection tank	l	100	100	130
Diaphragm	/	Yes	Yes	Yes
Drive wheel diameter	mm	250	250	250
Pivoting wheel diameter	mm	160	160	160
Net weight without batteries	kg	212	221	268
Number of batteries	no.	4	4	6
Voltage of batteries in series	V	24	24	36
Machine size	cm X/Y/Z	163x76x115,5	167x86x115,5	168x102x115,5
Total oscillation value	m/s²	<2,5	<2,5	<2,5

9. CE CONFORMITY DECLARATION

We hereby declare that the machine described below complies with the relevant basic safety and health requirements of the EU Directives, both in its basic design and construction as well as in the version put into circulation by us. This declaration shall cease to be valid if the machine is modified without our prior approval.

Product: Floor cleaner
Type: Premium Green Line

Relevant EU Directives

2006/42/CE
2004/108/CE
2000/14/CE

Applied harmonized standards

EN 50106:2009-07-01
EN 55014-1: 2007-06

Applied national standards

DIN EN 60335-1: 2007-02
DIN EN 60335-2-72
DIN EN 60529: 1991 + A1: 2000

10. SPECIAL INFORMATION FOR USING THE BATTERIES AND CHARGER

Do you know how much a set of batteries costs?

Between about 650 and 2000 € according to the size of your machine. Should you have armoured tube batteries, the cost of a set is between 2500 and 2100 €.

Reason enough, we think, to give these expensive energy units the necessary daily attention required, in order to achieve the greatest possible working life from them.

To ensure even greater protection for your batteries, we stock a battery condition indicator which shows the state of the battery at any given time. This instrument (type: BEM) is a panel type and can be fitted in the panel on any of our battery-powered machines.

Luminous diodes of various colours are used to indicate the different levels of voltage. The device can also be used to switch the brush motor(s) off automatically as soon as the battery reaches a fixed state of discharge. Please feel free to consult the staff at our local sales depots or dealers for information on using and fitting these instruments as well as on the way they work.

Points you really must take notice of:

- Never discharge the batteries too low.

Every battery should only be discharged to 70 or 80% of its rated capacity. You will overburden the batteries,

- a) if you use your machine too long, too often. How long you can safely work your machine, will be explained to you, when our service personnel installs your equipment. You can ask our service personnel at any time, or call our nearest service depot. For machines fitted with a BEM the brushes will automatically be switched off when the battery voltages becomes too low.

- b) if you use your machine regularly more than once within 24 hours to a certain extend. A good battery charger requires continuously approx. 10 - 12 hours (according to type) to recharge empty batteries. If you interrupt the charging process, the batteries will never become fully charged, and will be quickly ruined.

- c) if you do not recharge the batteries immediately after having used them to about 70 or 80% of their rated capacity. Empty batteries do not have the power for a further operation, and will be quickly ruined. For machines fitted with a BEM the brushes will automatically be switched off when the battery voltages becomes too low.
If you use your machine daily for (a) short period(s) only, ask at your nearest agency, or our service personnel. We will inform you as to the most practical way to use your charger to avoid premature corrosion of the battery.

- Storage of batteries

if batteries are taken out of service for a lengthy period they should be stored fully charged in a dry, frost-free room. To ensure the battery is always ready for use a choice of charging methods can be made:

- a) **A quarterly full charge.**
If loads are connected, e.g. BEM, a full charge could be needed after 3 weeks.

- b) Float charging at the instructed charging voltage.

- Correct connection of the battery charger.

Please take careful note that:

- d) the plug of the charger cable is firmly plugged into the machine;
- e) the mains plug is firmly fitted into the wall socket. Confirm that the wall socket has electrical feed overnight and hang a notice on the plug, saying, that during the charging period the plug, must not be removed;
- f) the battery charger will switch itself on automatically after 15 seconds.

Before leaving the machine, please check carefully, that all connections are properly made and that the charger is switched on. Many batteries have been damaged prematurely because something has been overlooked. Please read the operating instructions of the type of charger in use with you.

- Secure seating of the post terminals on the cables, that join the batteries together.

Loose battery post terminals are dangerous because a layer builds up that hinders the flow of electricity. When recharging the batteries, full electrical charge cannot flow, the batteries will not become fully charged and are therefore damaged prematurely. Should you find loose post terminals, please do not simply tighten them, but remove them, clean the post and the terminal inside and out, smear with battery grease and refit tightly.

- Run-in instruction

Note that brand-new batteries need a running-in period and thus can not yet supply full power during the first 8 - 10 discharges. Therefore, the machine should be kept off heavy duty jobs during that time.

Should you have any further questions about the handling of your battery machine, please call our nearest office or agency.

- *Never let the batteries get dry.

The electrolyte must cover the cell plates at all times, it should be at least 5/8 ths of an inch over the plates. Cell plates that are continuously dry or part dry, build up a layer that prevents the cells from charging, rendering the battery useless within a short time.

- ****Never overfill the batteries.***

Too much electrolyte is as bad as too less. Only top up to approx. 5/8 ths of an inch above the cell plates.

Important in breaching with battery acid - corrosive!

- ****Always top up the batteries with distilled water, never acid.***

The only thing that vaporises when the batteries are warm, is the distilled water, therefore it is only necessary to top up with distilled water. Topping up with acid, makes the electrolyte too strong, and causes corrosion on the cell plates.

Important in breaching with battery acid - corrosive!

*this does not apply to maintenance-free batteries

- ****Never top up with tap water.***

Tap water has an electrical conductivity and will destroy the batteries. You can purchase distilled water at Electrical Wholesalers, from us, or from Petrol Stations.

If you have any further questions about the handling of our battery machines then please contact your nearest **Gansow** representative or our head quarter in Unna / Germany.

*this does not apply to maintenance-free batteries

11. CONTROL AND MAINTENANCE OPERATIONS:

IMPORTANT !

Repairs should preferably be performed by qualified personnel.

Only original spare-parts may be used. Modification of the machine without the approval of the manufacturer or the use of unauthorised materials invalidates the warranty as the structural condition of the machine may differ from that described in the certificate

After any repair work by unauthorised personnel the machine must be officially approved by Gansow or a technician authorised by the company to confirm conformity with the original conditions and therefore the validity of the general terms of the warranty.

Before any cleaning or servicing work is carried out on the machine, disconnect the charger cable and remove the key from the key switch to guarantee operator safety.

IMPORTANT SAFEGUARDS

The following tasks should be carried out daily before or after each work session:

- remove dirty water and rinse out the tank,
- clean the machine (do not use water jets or water cleaners)
- rinse the suction hose by running water from inside the tank,
- charge battery and check that the battery terminals and power plug are securely in position
- clean the electrodes and check the level of the dirty water and foam,
- make sure the tank lid fits correctly to the tank.

Table of recommended checks, inspections and maintenance and schedule, based on daily use of about four hours;

Description of control	interval	interval	interval	interval	interval
	WK.LY	MTH.LY	4/MTH	6/MTH	YR.LY
1. General controls					
Check the fixing and condition of the brush	X				
Check for water leaks from the tanks			X		
Clean the solution tank filters	X				
Make sure the switches and indicator lights on the panel are working correctly	X				
Check that the squeegee blades are not worn or damaged	X				
Check that the squeegee is correctly adjusted and adheres to the ground when suction is activated	X				
Grease the head raising and squeegee lever rotation pins		X			
Make sure there are no foreign bodies in the drive wheels and check the tyres are not worn		X			
2. Motors					
Check, if possible, wear of the drive motor carbon brushes and replace if necessary			X		
Check wear of the brush motor carbon brushes and replace if necessary (battery powered models only)			X		
Check wear of the suction motor carbon brushes and replace if necessary			X		
3. Drive					
Ensure cables are not damaged or loose			X		

Description of controls	interval	interval	interval	interval	interval
	WK.LY	MTH.LY	4/MTH	6/MTH	YR.LY
4. Collection tank					
Make sure the drain hoses are not blocked	X				
Make sure the suction hose is not blocked		X			
5. Batteries					
Check the condition of the cables and the seal of the cell caps.		X			
If the machine is not used and the batteries are active, recharge every three months			X		
Top up the level of battery fluid in all cells. (not necessary with gel batteries)	X				
Grease the battery terminals (not necessary with gel batteries).			X		
Call the authorised Gansow technical assistance service for a full control				X	

VERKLEIDUNG/COVER

DATUM/DATE: 01/2011

BLATT/PAGE: 01

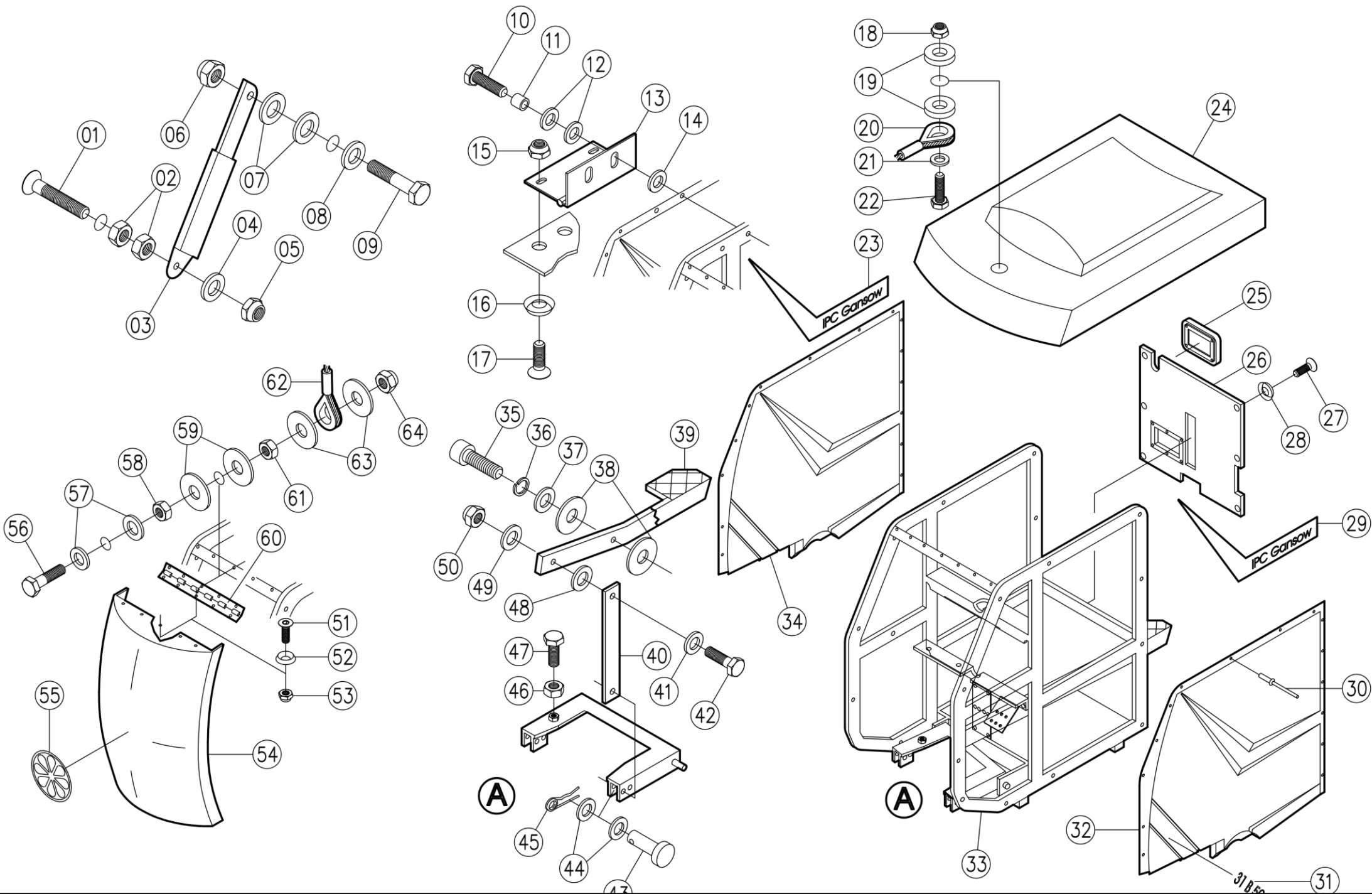

Verkleidung-Cover

Position	Menge	Artikel-Nr.	IPC	Bezeichnung	Description	bis / up to	ab / from
0001	1	05328	VTVT00173	Schraube, Senkkopf-, M 6 x 25	countersunk head screw, M 6 x 25		
0002	2	05096	VTDD00482	Mutter, Sechskant, M 6	hexagonal screw, M 6		
0003	1	01728	LAFN01252	Stütze, Aufstell-, für vorderen Deckel	support for front lid		
0004	1	05119	VTRS00041	Scheibe, Unterleg-, M 6	washer, M 6		
0005	1	05218	VTDD86633	Mutter, Sechskant-, selbstsichernd, M 6	hexagonal nut, selfsealing, M 6		
0006	1	05218	VTDD86633	Mutter, Sechskant-, selbstsichernd, M 6	hexagonal nut, selfsealing, M 6		
0007	2	05119	VTRS00041	Scheibe, Unterleg-, M 6	washer, M 6		
0008	1	05119	VTRS00041	Scheibe, Unterleg-, M 6	washer, M 6		
0009	1	05012	VTVT00444	Schraube, Sechskant, M 6 x 20	hexagonal screw, M 6 x 20		
0010	4	05503	VTVT14095	Schraube, Zylinderkopf-, M 6 x 16	allen cap screw, M 6 x 16		
0011	4	01693	LAFN01250	Hülse, Distanz-, 8 x 3 mm	spacer sleeve, 8 x 3 mm		
0012	8	05119	VTRS00041	Scheibe, Unterleg-, M 6	washer, M 6		
0013	2	14278	CEVR00018	Deckelscharnier, 80 x 80 x 1,5 mm	hinge for top lid, 80 x 80 x 1,5 mm		
0014	4	05119	VTRS00041	Scheibe, Unterleg-, M 6	washer, M 6		
0015	4	05217	VTDD00026	Mutter, Sechskant-, selbstsichernd, M 5	hexagonal nut, selfsealing, M 5		
0016	4	05557	VTRS00067	Rosette, M 5, schwarz	collar, M 5, black		
0017	4	05065		Schraube, Linsensenkkopf-, M 5 x 18	raised countersunk head screw, M 5 x 18		
0018	1	05218	VTDD86633	Mutter, Sechskant-, selbstsichernd, M 6	hexagonal nut, selfsealing, M 6		
0019	2	05119	VTRS00041	Scheibe, Unterleg-, M 6	washer, M 6		
0020	1	13449	CMCV00071	Seil, Edelstahl-, für oberen Deckel	cable rope for top lid		
0021	1	05119	VTRS00041	Scheibe, Unterleg-, M 6	washer, M 6		
0022	1	05259	VTVT01531	Schraube, Sechskant, M 6 x 16	hexagonal screw, M 6 x 16		
0023	1	31207		Aufkleber, Keil, grün, rechts, 31 B	sticker, wedge form, green, right, 31 B		
0024	1	31204		Deckel, oberer-, grün, 31 B	top lid, green, 31 B		
0025	1	06925	MEVR00331	Deckel für Sicherungsautomaten	lid for automatic cut-out		
0026	1	31205		Platte, Abdeck-, am Gestell, 31 B	cover at the frame, 31 B		
0027	1	05461	VTVT00184	Schraube, Selbstschneidend, M 5 x 16	self tapping screw, M 5 x 16		

0028	1	05557	VTRS00067	Rosette, M 5, schwarz	collar, M 5, black		
0029	1	31206		Aufkleber, Keil, grün, links, 31 B	sticker, wedge form, green, left, 31 B		
0030	30	05157	VTVR00073	Niete, Blind-, 4 x 12	rivet, 4 x 12 mm		
0031	2	31208		Aufkleber, grün, 31 B 50	sticker, green, 31 B 50		
0032	1	31209		Seitenverkleidung, links, 31 B	side cover, left, 31 B		
0033	1	24000		Gestell, 31 B	frame, 31 B		
0034	1	31210		Seitenverkleidung, rechts, 31 B	side cover, right, 31 B		
0035	1	05209	VTVT00158	Schraube, Zylinderkopf-, M 10 x 25	allen cap screw, M 10 x 25		
0036	1	05133	VTRS01081	Federring, M 10	spring washer, M 10		
0037	1	05116	VTRS00505	Scheibe, Unterleg-, M 10	washer, M 10		

VERKLEIDUNG/COVER

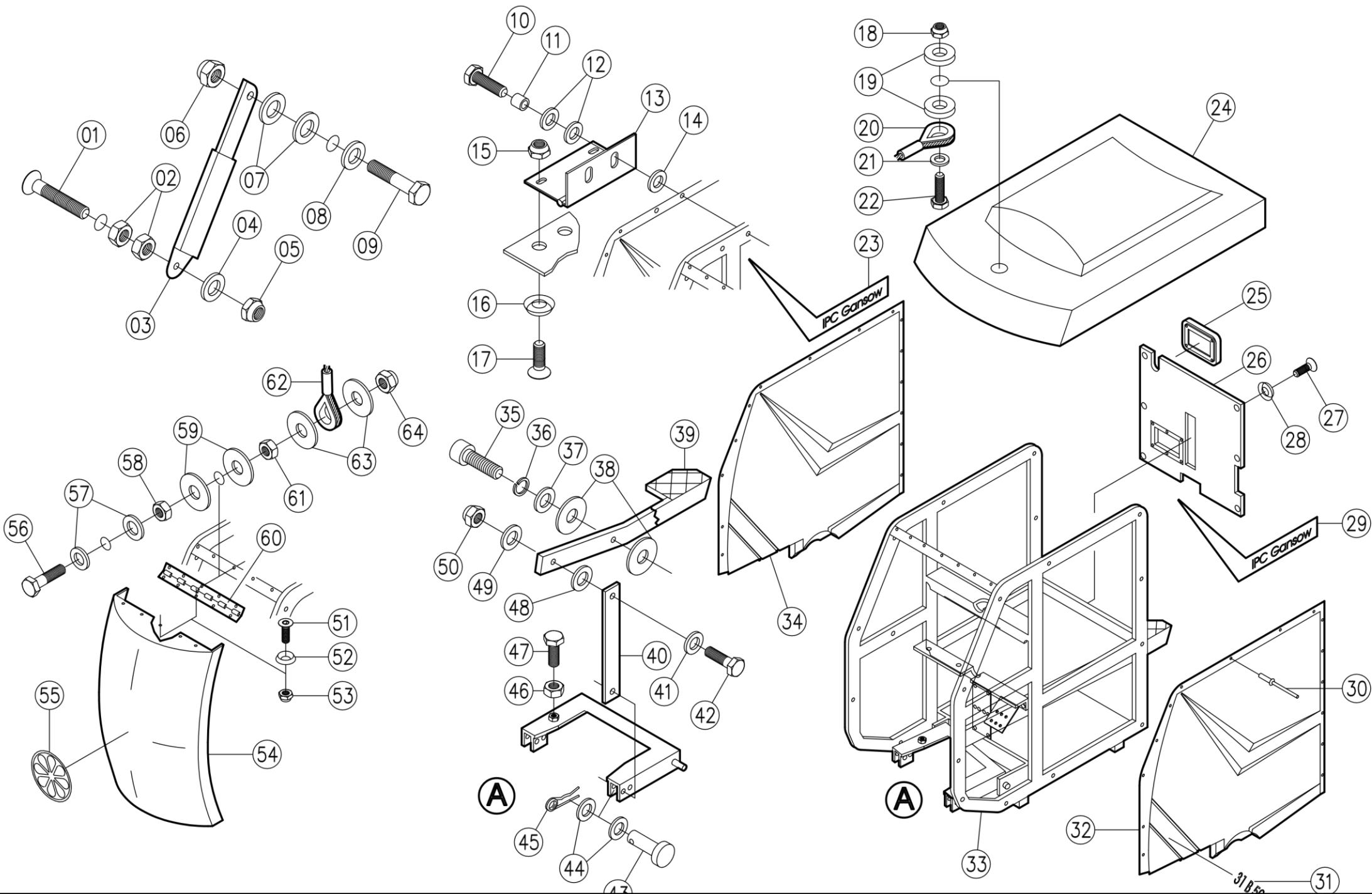

0038	2	05114	VTRS00040	Scheibe, Unterleg-, 12 x 18 x 1 mm	washer, 12 x 18 x 1 mm		
0039	1	22256	LAFN01464	Hebel für Bürstenkopf, 31 B	brush head lever, 31 B		
0040	1	20489	LAFN01392	Verbindungsglasche am Bürstenkopf	connection link		
0041	1	05116	VTRS00505	Scheibe, Unterleg-, M 10	washer, M 10		
0042	1	05016	VTVT00141	Schraube, Sechskant, M 10 x 30	hexagonal screw, M 10 x 30		
0043	1	01786	VTVR00062	Bolzen mit Kopf, 12 x 55 mm	bolt with head, 12 x 55 mm		
0044	2	05126	VTRS00506	Scheibe, Unterleg-, M 12	washer, M 12		
0045	1	01677	VTVR00061	Federstecker, 3,2 mm	spring clip, 3,2 mm		
0046	1	05103	VTDD01682	Mutter, Sechskant, M 12	hexagonal screw, M 12		
0047	1	05303	VTVT00167	Schraube, Zylinderkopf-, M 12 x 40	allen cap screw, M 12 x 40		
0048	1	05116	VTRS00505	Scheibe, Unterleg-, M 10	washer, M 10		
0049	1	05116	VTRS00505	Scheibe, Unterleg-, M 10	washer, M 10		
0050	1	05219	VTDD00027	Mutter, Sechskant-, selbstsichernd, M 10	hexagonal nut, selfsealing, M 10		
0051	5	05058	VTVT00146	Schraube, Linsensenkkopf-, M 5 x 14	raised countersunk head screw, M 5 x 14		
0052	5	05557	VTRS00067	Rosette, M 5, schwarz	collar, M 5, black		
0053	5	05217	VTDD00026	Mutter, Sechskant-, selbstsichernd, M 5	hexagonal nut, selfsealing, M 5		
0054	1	31211		Deckel, vorderer-, grün, 31 B	front lid, green, 31 B		
0055	1	16597		Aufkleber, Limette	sticker, lime		
0056	1	05038		Schraube, Zylinderkopf-, M 5 x 30	allen cap screw, M 5 x 30		
0057	2	05117	VTRS00502	Scheibe, Unterleg-, M 5	washer, M 5		
0058	1	05098	VTDD01678	Mutter, Sechskant, M 5	hexagonal screw, M 5		
0059	2	05446	VTRS00056	Scheibe, Unterleg-, 5 x 15 mm	washer, 5 x 15 mm		
0060	1	14841	CEVR00021	Scharnier für vorderen Deckel, 340 mm	hinge for front lid, 340 mm		
0061	1	05098	VTDD01678	Mutter, Sechskant, M 5	hexagonal screw, M 5		
0062	1	13449	CMCV00071	Seil, Edelstahl-, für oberen Deckel	cable rope for top lid		
0063	2	05446	VTRS00056	Scheibe, Unterleg-, 5 x 15 mm	washer, 5 x 15 mm		
0064	1	05217	VTDD00026	Mutter, Sechskant-, selbstsichernd, M 5	hexagonal nut, selfsealing, M 5		

85612

31 B 50

BLATT/PAGE 2

GESTELL/FRAME

BLATT/PAGE: 02

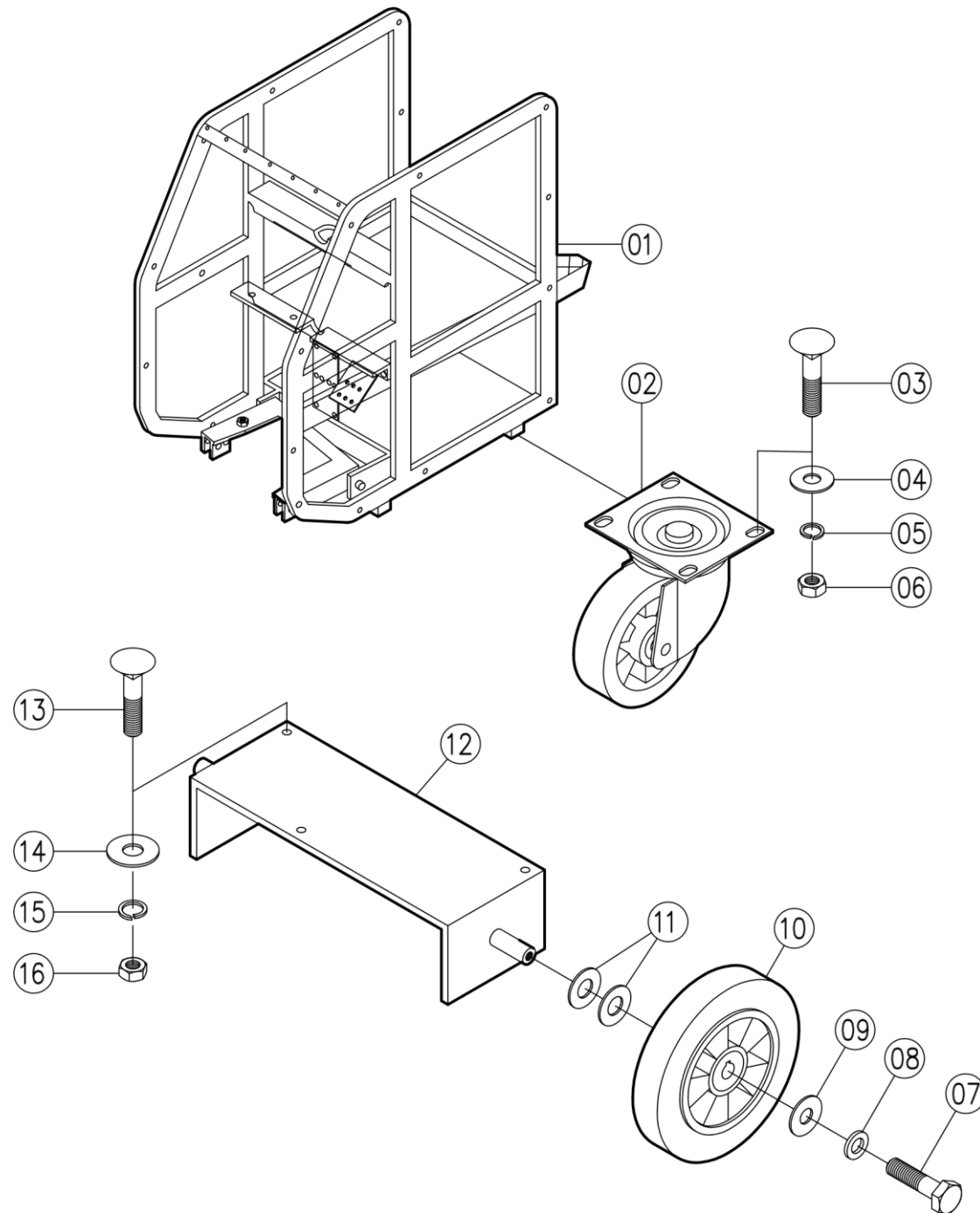

Position	Menge	Artikel-Nr.	IPC	Bezeichnung	Description	bis / up to	ab / from
0001	1	24000		Gestell 31 B	frame, 31 B		
0002	1	14330	RTRT00063	Lenkrolle, 125 mm	caster wheel, 125 mm		
0003	4	75258	VTVT00326	Schraube, Schloss-, M 8 x 30	carriage bolt, M 8 x 30		
0004	4	75057	VTRS63243	Scheibe, Unterleg-, 8 x 24 mm	washer, 8 x 24 mm		
0005	4	05136	VTRS01080	Federring, M 8	spring washer, M 8		
0006	4	05094	VTDD10776	Mutter, Sechskant-, M 8	hexagonal nut, M 8		
0007	2	75067	VTVT00243	Schraube, Sechskant-, M 6 x 16	hexagonal screw, M 6 x 16		
0008	2	05296	VTRS00071	Federring, M 6	spring washer, M 6		
0009	2	05127	VTRS00044	Scheibe, Unterleg-, 6 x 30 mm	washer, 6 x 30 mm		
0010	2	14335	RTRT00065	Rad, 160 mm	wheel, 160 mm		
0011	4	75133	VTRS00116	Scheibe, Unterleg-, 12 x 24 mm	washer, 12 x 24 mm		
0012	1	22292	LAFN01471	Achse mit Grundplatte, 31 B 46	axle with base plate, 31 B 46		
0013	3	05075	VTVT00155	Schraube, Schloss-, M 8 x 25	carriage bolt, M 8 x 25		
0014	3	75057	VTRS63243	Scheibe, Unterleg-, 8 x 24 mm	washer, 8 x 24 mm		
0015	3	05136	VTRS01080	Federring, M 8	spring washer, M 8		
0016	3	05094	VTDD10776	Mutter, Sechskant-, M 8	hexagonal nut, M 8		

WASSERTANK/TANK

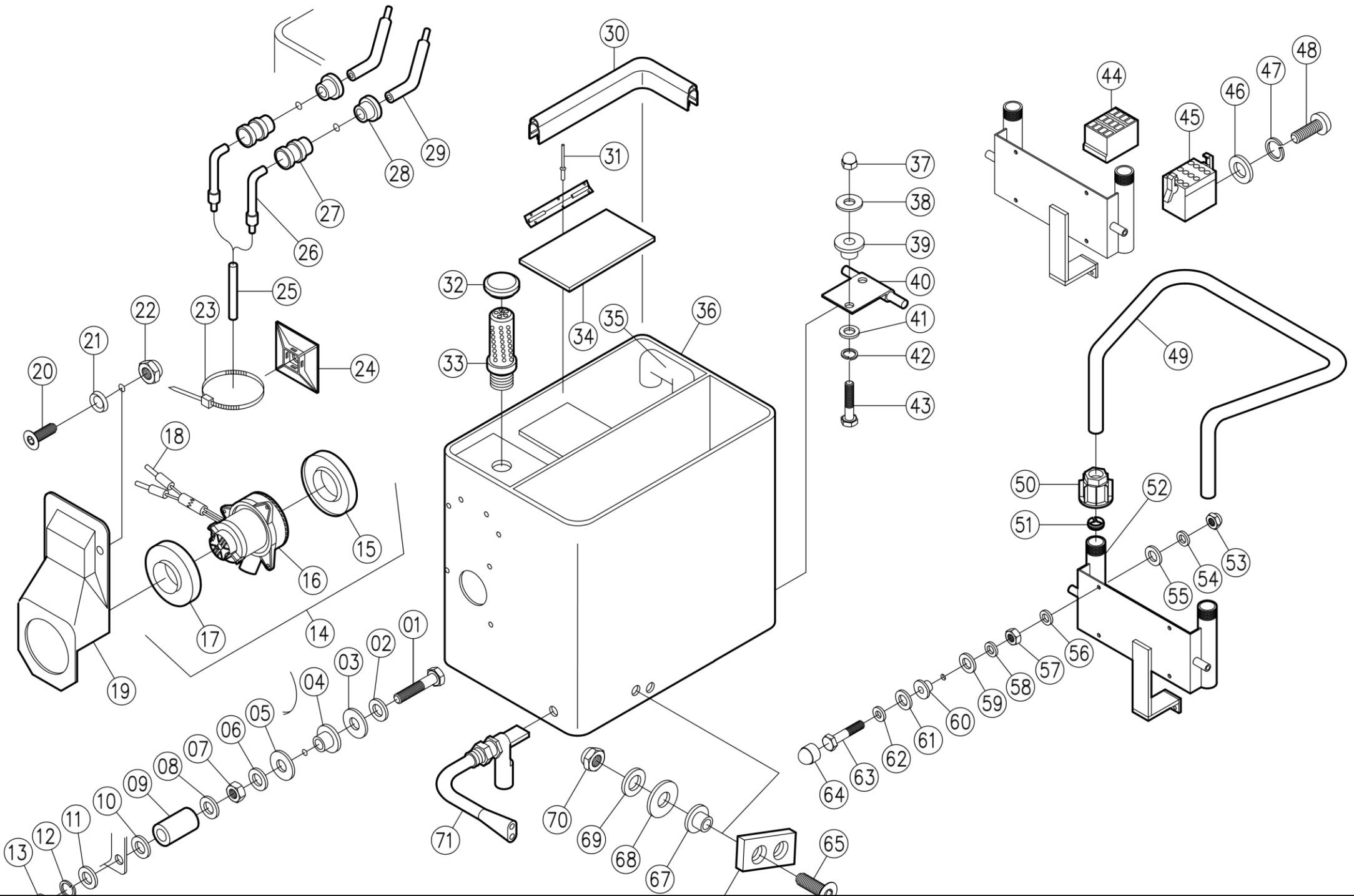

Wassertank-Tank

Position	Menge	Artikel-Nr.	IPC	Bezeichnung	Description	bis / up to	ab / from
0001	3	05241	VTVT06238	Schraube, Sechskant, M 6 x 35	hexagonal screw, M 6 x 35		
0002	3	05123	VTRS00043	Scheibe, Unterleg-, M 6	washer, M 6		
0003	3	05120	VTRS00042	Scheibe, Unterleg-, M 8	washer, M 8		
0004	3	05350	VTRS00052	Schraubensicherungsring, M 6	packing ring, plastic, M 6		
0005	3	05120	VTRS00042	Scheibe, Unterleg-, M 8	washer, M 8		
0006	3	05123	VTRS00043	Scheibe, Unterleg-, M 6	washer, M 6		
0007	3	05096	VTDD00482	Mutter, Sechskant, M 6	hexagonal screw, M 6		
0008	3	05123	VTRS00043	Scheibe, Unterleg-, M 6	washer, M 6		
0009	3	01712	LAFN01251	Hülse, 15/1,5 x 46 mm	bushing, 15/1,5 x 46 mm		
0010	3	05123	VTRS00043	Scheibe, Unterleg-, M 6	washer, M 6		
0011	3	05123	VTRS00043	Scheibe, Unterleg-, M 6	washer, M 6		
0012	3	05131	VTRS01079	Federring, M 6	spring washer, M 6		
0013	3	05096	VTDD00482	Mutter, Sechskant, M 6	hexagonal screw, M 6		
0014	1	40508	PMVR00454	Motor, Saug-, 24 V, 2-stufig, komplett	suction motor, 24 V, 2-stages, complete		
0015	1	01448	GUVR00027	Dichtungsring für Turbine	sealing ring for suction motor		
0016	1	12757	MOMO00016	Motor, Saug-, 24 V, 2-stufig	suction motor, 24 V, 2-stages		
0017	1	01448	GUVR00027	Dichtungsring für Turbine	sealing ring for suction motor		
0018	2	06463	MEVR00199	Hülse, Aderend-, 2,5 mm ²	cable end, 2,5 mm ²		
0019	1	03981	MPVR01046	Haube für Saugmotor	cover for suction motor		
0020	2	05321		Schraube, Senkkopf-, M 6 x 20	countersunk head screw, M 6 x 20		
0021	2	75168	VTRS00118	Rosette, M 6, schwarz	collar, M 6, black		
0022	2	05240	VTDD05907	Mutter, Hut-, M 6	cap nut, M 6		
0023	6	06365	FSVR00015	Abbinder	cable strap		
0024	6	14733		Abbinderhalter	holder for cable strap		
0025	1	06724	MEVR00239	Elektrodenkabel	probe cable		
0026	2	06784	MEVR00257	Rundsteckhülsen, PIDG-NYL	socket, PIDG-NYL		
0027	2	01733	MEVR00161	Verschraubung-, Kabel-, PG 7	probe holder, PG 7		

0028	2	13382	GUVR00034	Elektrodendichtung	probe sealing		
0029	1	40985	DBDB00918	Elektroden, Satz	probe, set		
0030	1	31213		Tankdichtung, Green Line, Meterware	sealing for tank, Green Line, by the meter		
0031	2	05238		Blindniete, 3 x 14 mm	Rivet, 3 x 14 mm		
0032	1	13458	RCVR00120	Kappe, Abdeck-, 51 mm, schwarz	cover, 51 mm, black		
0033	1	04374	MPVR01049	Sieb, komplett, 130 mm	filter, complete, 130 mm		
0034	1	HT1020	MPVR04735	Klappe im SW-Tank	plate inside the dirt water tank		
0035	2	01620	RCVR00088	Rohrbogen, 90 Grad, 40 mm, PVC	elbow, 90 degree, 40 mm, PVC		
0036	1	31212		Tank, 31 B	tank, 31 B		
0037	4	05221	VTDD36474	Mutter, Hut-, M 8	cap nut, M 8		

WASSERTANK/TANK

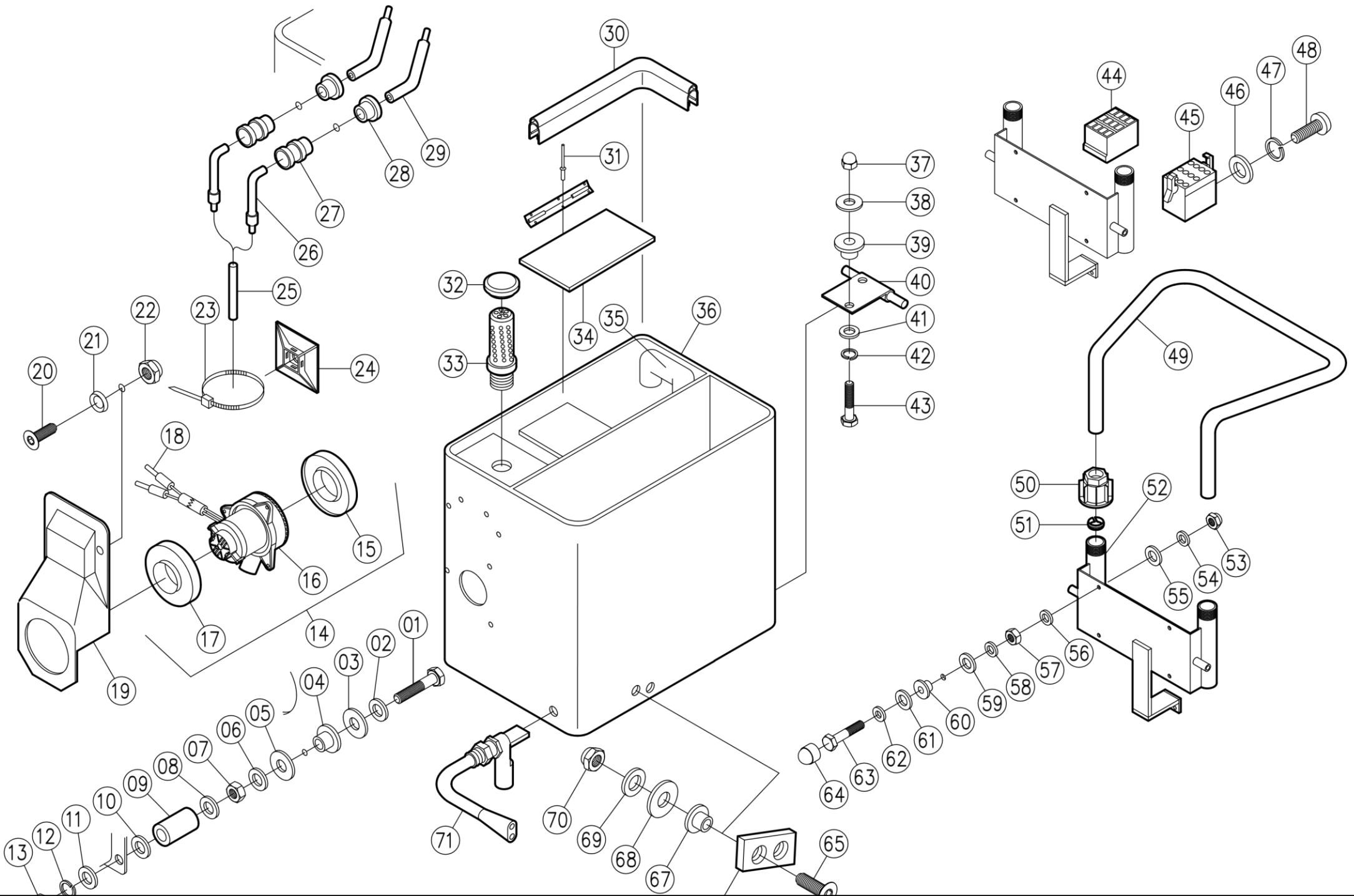

0038	4	05121	VTRS17677	Scheibe, Unterleg-, M 10	washer, M 10		
0039	4	05351	VTRS00053	Schraubensicherungsring, M 8	packing ring, plastic, M 8		
0040	2	02060	CEVR00016	Tankscharnier	tank hinge		
0041	4	05118	VTRS00503	Scheibe, Unterleg-, M 8	washer, M 8		
0042	4	05136	VTRS01080	Federring, M 8	spring washer, M 8		
0043	4	05250	VTVT00449	Schraube, Sechskant, M 8 x 35	hexagonal screw, M 8 x 35		
0044	1	31245		Buchse, 9-Polig	socket, 9-poles		
0045	1	31246		Stecker, 9-Polig	plug, 9-poles		
0046	4	05117	VTRS00502	Scheibe, Unterleg-, M 5	washer, M 5		
0047	4	05130	VTRS08013	Federring, M 5	spring washer, M 5		
0048	4	05319	VTVT00170	Schraube, Zylinderkopf-, M 5 x 8	allen cap screw, M 5 x 8		
0049	1	40903	PMQE00148	Lenkgriff, 31 B	steering handle, 31 B		
0050	2	13254	VTVR00086	Mutter, Überwurf-, für Lenkgriff	screw cap for steering handle		
0051	2	13261	PVVR00002	Klemmring, 25 mm	clamping ring, 25 mm		
0052	1	21345	LAFN01406	Lenkgriff Unterteil, 31/41/61 B/BF	steering handle, bottom part, 31/41/61 B/BF		
0053	4	05218	VTDD86633	Mutter, Sechskant-, selbstsichernd, M 6	hexagonal nut, selfsealing, M 6		
0054	4	05123	VTRS00043	Scheibe, Unterleg-, M 6	washer, M 6		
0055	4	05119	VTRS00041	Scheibe, Unterleg-, M 6	washer, M 6		
0056	4	05119	VTRS00041	Scheibe, Unterleg-, M 6	washer, M 6		
0057	4	05099		Mutter, Sechskant-, M 6	hexagonal nut, M 6		
0058	4	05123	VTRS00043	Scheibe, Unterleg-, M 6	washer, M 6		
0059	4	05120	VTRS00042	Scheibe, Unterleg-, M 8	washer, M 8		
0060	4	05350	VTRS00052	Schraubensicherungsring, M 6	packing ring, plastic, M 6		
0061	4	05120	VTRS00042	Scheibe, Unterleg-, M 8	washer, M 8		
0062	4	05123	VTRS00043	Scheibe, Unterleg-, M 6	washer, M 6		
0063	4	05017		Schraube, Sechskant, M 6 x 30	hexagonal screw, M 6 x 30		
0064	4	05359	MPVR60346	Abedckkappe, Kunststoff-, M 6	cap for hexagonal nut, M 6		

0065	2	05327	VTVT00179	Schraube, Senkkopf-, M 8 x 30	countersunk head screw, M 8 x 30		
0066	1	03515	LAFN01281	Tankhalter	buffer for tank		
0067	2	05351	VTRS00053	Schraubensicherungsring, M 8	packing ring, plastic, M 8		
0068	2	05121	VTRS17677	Scheibe, Unterleg-, M 10	washer, M 10		
0069	2	05242	VTRS00504	Scheibe, Unterleg-, M 8, VA	washer, M 8, stainless steel		
0070	2	05221	VTDD36474	Mutter, Hut-, M 8	cap nut, M 8		
0071	1		MECI00516	Schalter, Schwimmer-, SW-Tank,	float switch inside the clean water tank		

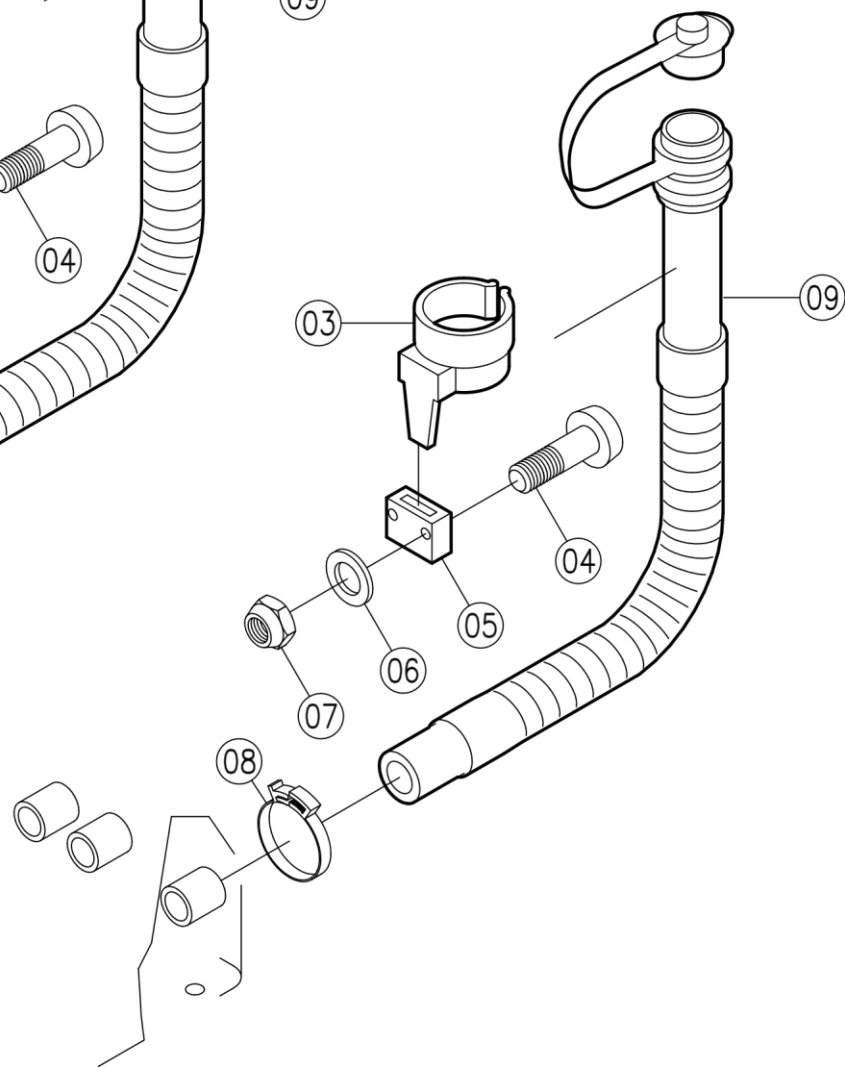
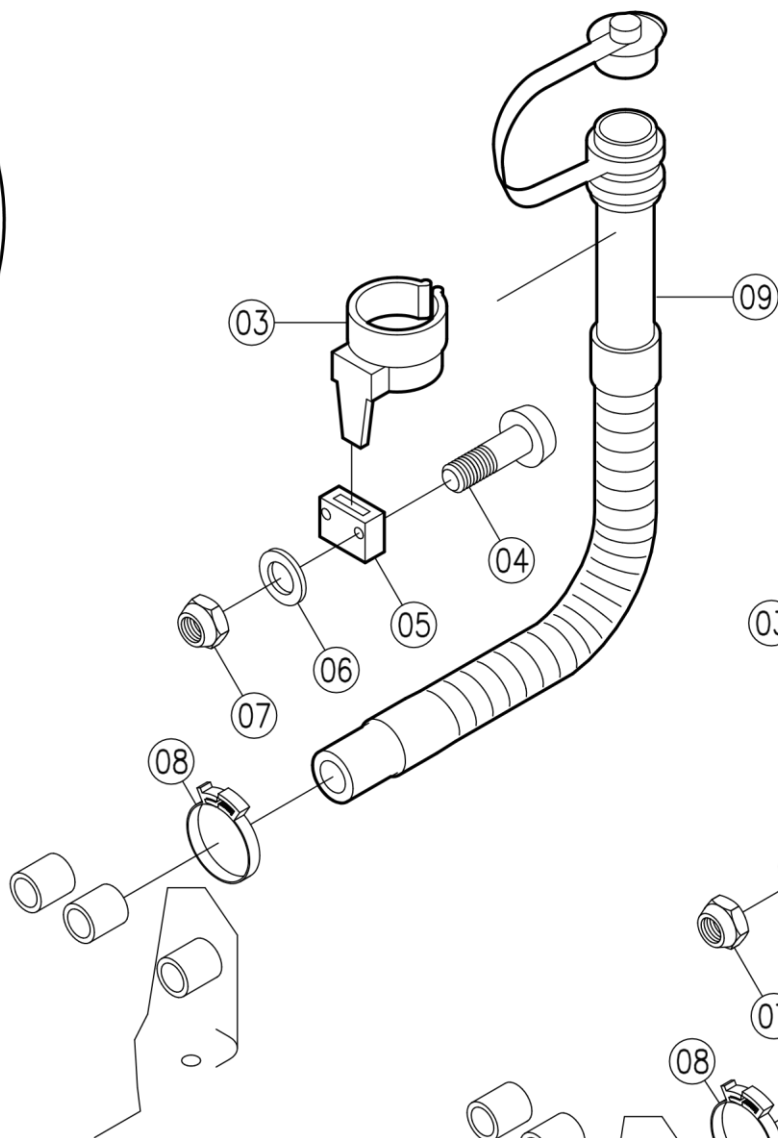
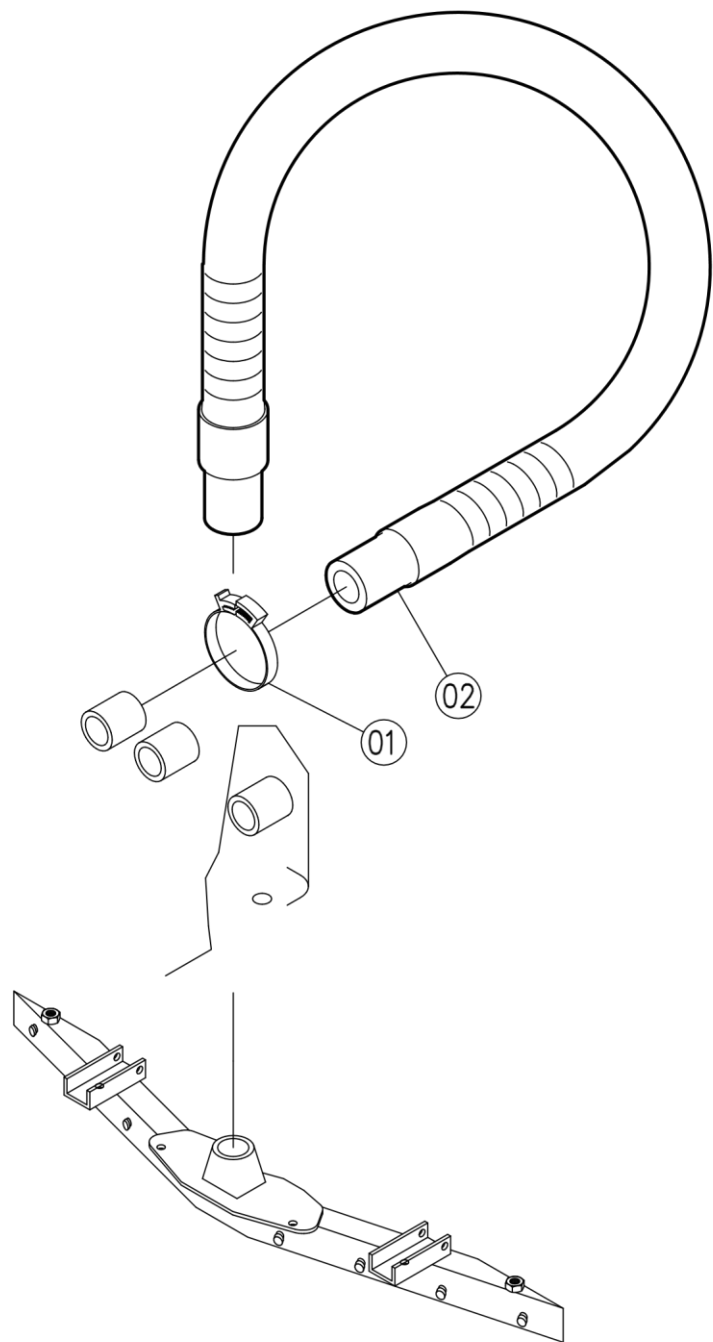

Schlaeuche-Hoses

Position	Menge	Artikel-Nr.	IPC	Bezeichnung	Description	bis / up to	ab / from
0001	1	13933	MEVR00370	Schlauchklemme, 44 - 47,5 mm	hose clip, 44 - 47,5 mm		
0002	1	14716	TBFX00011	Schlauch, Saug-, 720 mm	suction hose, 720 mm		
0003	2	14672	MPVR01097	Clips, Schlauchhalterung-,	hose holding clip		
0004	4	05027	VTVT00877	Schraube, Zylinderkopf-, M 4 x 20	slotted head screw, M 4 X 20		
0005	2	14673	RCVR00125	Clips, Gegenstück,	clip counter part		
0006	4	75027	VTRS00515	Scheibe, Unterleg-, M 4	washer, M 4		
0007	4	05216	VTDD15925	Mutter, Sechskant-, M 4	hexagonal nut, M 4		
0008	2	13933	MEVR00370	Schlauchklemme, 44 - 47,5 mm	hose clip, 44 - 47,5 mm		
0009	2	16799		Schlauch, Ablass-, 600 mm	drain hose, 600 mm		

SCHALTKASTEN/SWITCH BOX

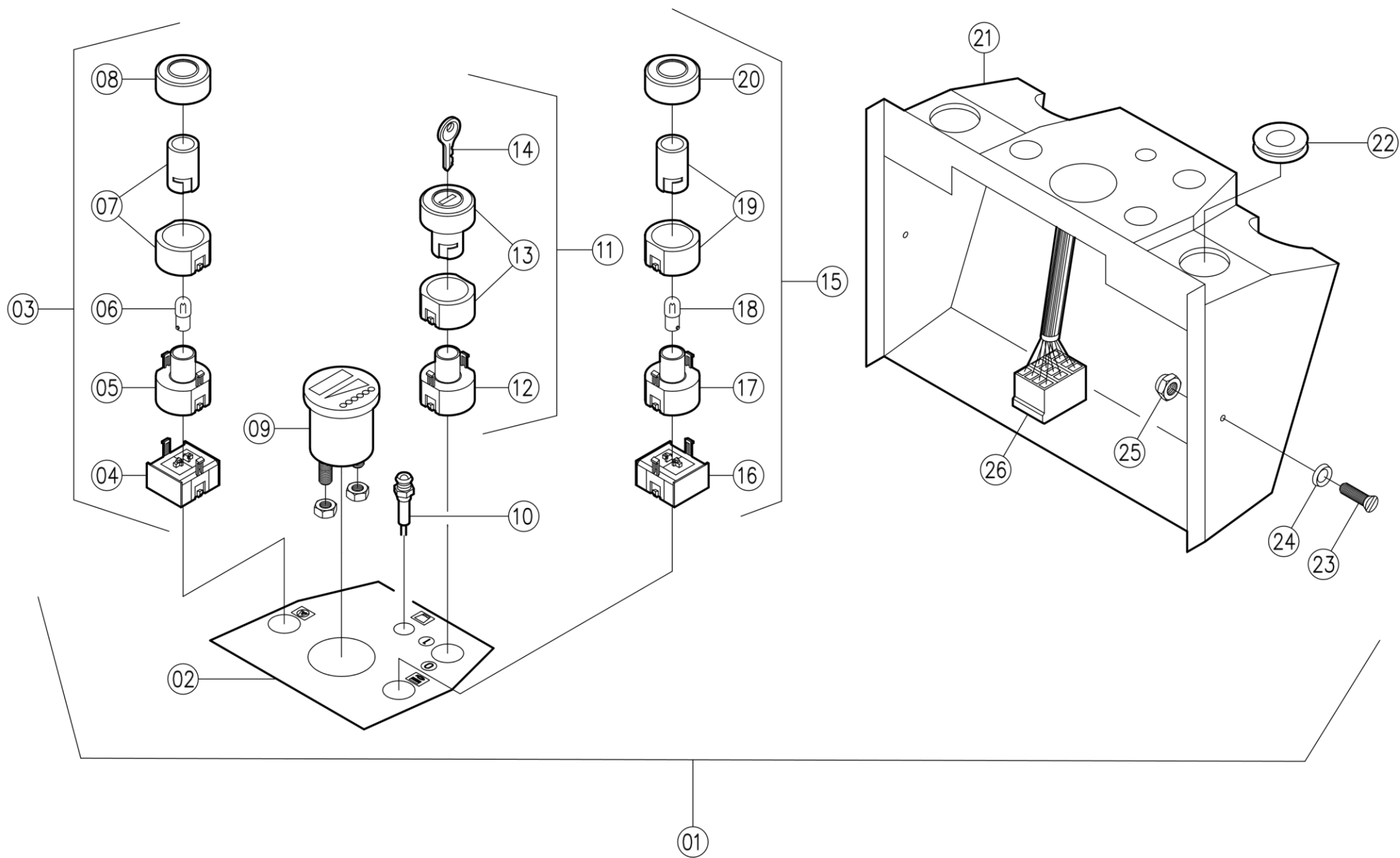

Schaltkasten-Switch box

Position	Menge	Artikel-Nr.	IPC	Bezeichnung	Description	bis / up to	ab / from
0001	1	31200		Schaltkasten, komplett, 31 B	switch box, complete, 31 B		
0002	1	31201		Aufkleber, Schaltpult, 31/41 B	sticker, switch board, 31/41 B		
0003	1		KTRI15040	Schalter, Turbinen-, komplett	switch, turbine, complete		
0004	1		MECI00506	Schalter, Unterteil,	switch, bottom part		
0005	1		MECI00507	Lampenfassung	lamp socket		
0006	1	06345	MEVR00193	Lampenbirne, 2W, 30V	light bulb, 2W, 30V		
0007	1		MECI00501	Schalter, Oberteil,	switch, upper part		
0008	1		MECI00503	Schutzkappe, Schalter	protection cap		
0009	1	16278	MESB00025	Batterieentladeanzeiger, 24 V	battery discharge indicator		
0010	1	11738		LED, rot	LED, red		
0011	1		KTRI15039	Schalter, Schlüssel-, komplett	key switch, complete		
0012	1		MECI00504	Schlüsselschalter, Unterteil,	key switch, bottom part		
0013	1		MECI00505	Schlüsselschalter, Oberteil,	key switch, upper part		
0014	1		AZMC00023	Schlüssel für Schlüsselschalter	key for key switch		
0015	1		KTRI15038	Schalter, Bürsten-, komplett	switch, brush, complete		
0016	1		MECI00502	Schalter, Unterteil,	switch, bottom part		
0017	1		MECI00507	Lampenfassung	lamp socket		
0018	1	06345	MEVR00193	Lampenbirne, 2W, 30V	light bulb, 2W, 30V		
0019	1		MECI00501	Schalter, Oberteil,	switch, upper part		
0020	1		MECI00503	Schutzkappe, Schalter	protection cap		
0021	1	31202		Schaltkasten, 31 B	switch box, 31 B		
0022	2	13486	GUVR00035	Dichtung für Lenkgriff	sealing for steering handle		
0023	2	75021	VTVT00234	Schraube, Senkkopf-, M 5 X 16	counter sunk screw, M 5 X 16		
0024	2	05557	VTRS00067	Rosette, M 5, schwarz	collar, M 5, black		
0025	2	05098	VTDD01678	Mutter, Sechskant-, M 5	hexagonal nut, M 5		
0026	1	31246		Stecker, 9-Polig	plug, 9-poles		

85612

31 B 50

BLATT/PAGE 7

VERDRÄHTUNG/WIRING

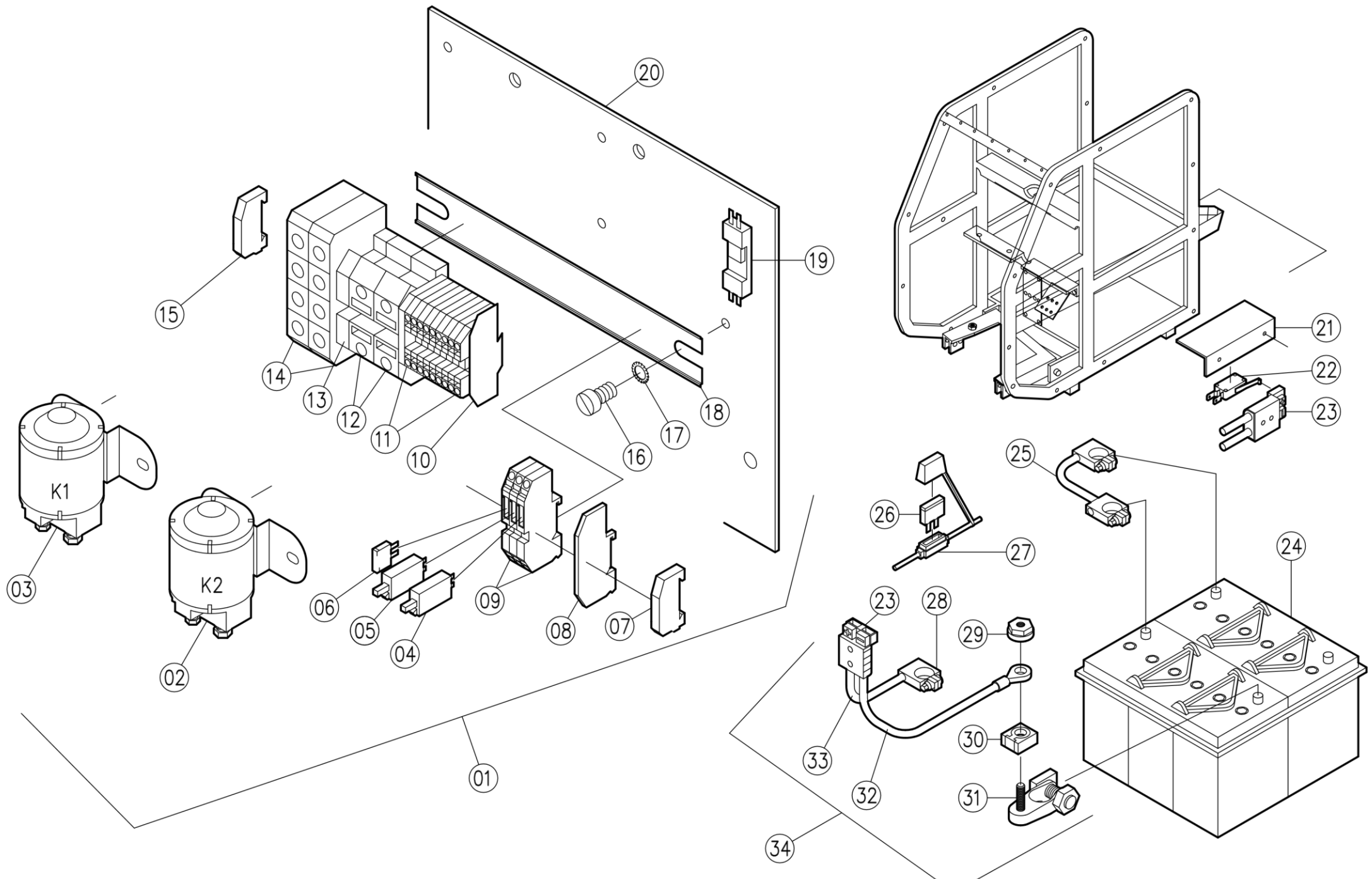

Verdrahtung-Wiring

Position	Menge	Artikel-Nr.	IPC	Bezeichnung	Description	bis / up to	ab / from
0001	1	31227		Verdrahtungsplatte, komplett, 31 B	wiring plate, complete, 31 B		
0002	1	06328	MECI00053	Schütz, 124 A	contactor, 124 A		
0003	1	06328	MECI00053	Schütz, 124 A	contactor, 124 A		
0004	1	14643	MEVR00379	Sicherungsautomat, 25 A	automatic fuse, 25 A		
0005	1	14643	MEVR00379	Sicherungsautomat, 25 A	automatic fuse, 25 A		
0006	1	70241	MEVR00585	Sicherung, 7,5 A	fuse, 7,5 A		
0007	1	06619	LAFN01302	Endklammer für Tragschiene	limit angle for terminalline		
0008	2	13841	MEVR00369	Platte, Abschluss- u. Zwischen-, orange	end plate for terminalline		
0009	3	13840	MEVR00368	Sicherungsklemme, 2-Leiter	fuse clamp, 2 conductor		
0010	1	13841	MEVR00369	Platte, Abschluss- u. Zwischen-, orange	end plate for terminalline, orange		
0011	8	06615	MEVR00224	Klemme, Durchgangs-, 2,5 mm ²	line-up terminal, 2,5 mm ²		
0012	2	06616	MEVR00225	Klemme, Durchgangs-, 6 mm ²	line-up terminal, 6 mm ²		
0013	1	06617	MEVR00226	Platte, Abschluss- u. Zwischen-,	end plate for terminalline,		
0014	2	12460	MEVR00355	Klemme, Durchgangs-, 35 mm ²	line-up terminal, 35 mm ²		
0015	1	06619	LAFN01302	Endklammer für Tragschiene	limit angle for terminalline		
0016	2	05445	VTVT00182	Schraube, Linsenkopf-, M 5 x 6	raised countersunk screw, M 5 x 6		
0017	2	05140	VTRS00046	Fächerscheibe, M 5	serrated lock washer, M 5		
0018	1	06235	MEVR62076	Tragschiene	terminal line		
0019	1	14254	MECE00106	Schaumabschaltungsplatine	pcb for overfilling protection		
0020	1	24006		Grundplatte, Verdrahtungs-, 31 B	wiring plate, drilled, 31 B		
0021	1	24028		Platte-, Befestigungs-, Mikroschalter	fixing plate for microswitch		
0022	1	16433		Mikroschalter am Ladestecker	microswitch at charging plug		
0023	1	11333	MEVR00341	Stecker, Lade-, 50 A, rot	charging plug, 50 A, red		
0024	2	11295	BAAC00020	Batterie, 12V/70Ah	battery, 12V/70 Ah		
0025	1	14844	MEVR00385	Kabel, Verbindungs-, für 2 x 12 V Batterien	cable conection for 2 x 12 V batteries		
0026	1	70164	MEVR00564	Sicherung, 2 A	fuse, 2 A		

0027	1	14171	MEVR00377	Halter, Flachstecksicherungs-, mit Kabel	fuse holder with cable		
0028	1	01724	MEVR00160	Polklemme "Minus"	post terminal, minus		
0029	1	06920	VTDD00030	Isoliermutter für Sicherungseinsatz	insulating nut for fuse insert		
0030	1	06918	MEVR00329	Sicherungseinsatz, 75 A	fuse insert, 75 A		
0031	1	06957	MEVR00337	Batterieklemme, 1-fach, plus	post terminal, plus		
0032	1	06264		Kabel, rot, 10 mm ²	cable, red, 10 mm ²		
0033	1	06500	MEVR00209	Kabel, schwarz, 10 mm ²	cable, blackred, 10 mm ²		
0034	1	31203		Batteriekabel, komplett, 31 B	battery cable, complete, 31 B		

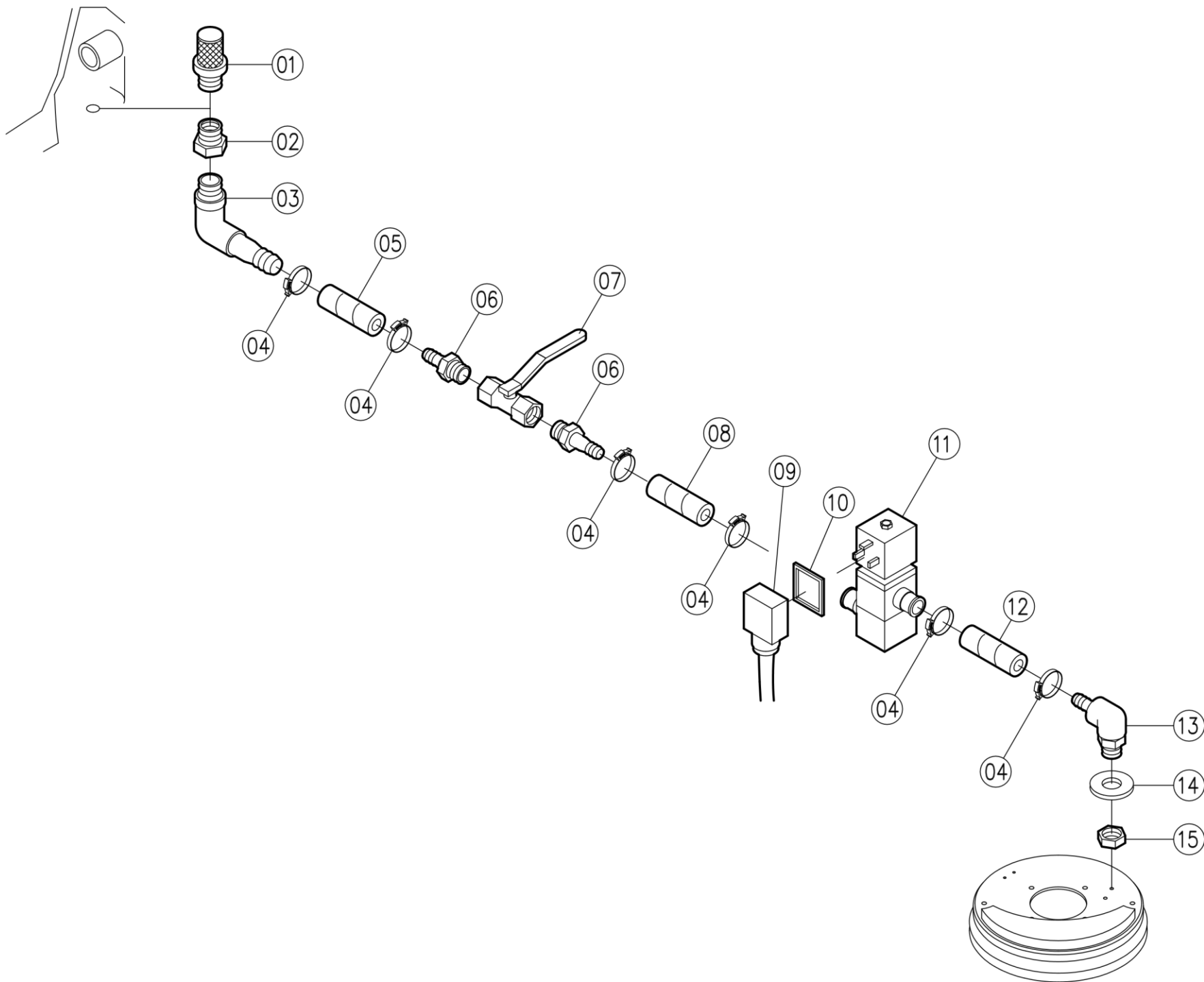

Magnetventil-Solenoid valve

Position	Menge	Artikel-Nr.	IPC	Bezeichnung	Description	bis / up to	ab / from
0001	1	01399	FTAC00001	Stand-Sieb, 1/2"	strainer, 1/2", for clean water tank		
0002	1	01756	RCVR00091	Reduzierstück, 3/4" x 1/2"	reducer, 3/4 " x 1/2 "		
0003	1	12476	RCVR00109	Winkel-Einschraubstutzen, 12 mm	elbow, 90 degree, 12mm		
0004	6	13935	MEVR00372	Schlauchklemme, 18,2 - 20,5 mm	hose clip, 18,2 - 20,5 mm		
0005	1	01705	TBBP00045	Schlauch, PVC, 1/2"	hose, PVC, 1/2"		
0006	2	12847	RCVR00113	Schlauchtülle, 12 mm	hose liner, 12 mm		
0007	1	13964	RCGR00017	Kugelhahn, 1/2"	globe valve, 1/2"		
0008	1	01705	TBBP00045	Schlauch, PVC, 1/2"	hose, PVC, 1/2"		
0009	2	40912	DBDB00909	Magnetventilkabel	cable for solenoid valve,		
0010	1	13923	GUVR00045	Dichtung für Magnetventilstecker	sealing for solenoid valve		
0011	1	13144	MECI00071	Magnetventil, 24V, 1/2"	solenoid valve, 24V, 1/2"		
0012	1	01705	TBBP00045	Schlauch, PVC, 1/2"	hose, PVC, 1/2"		
0013	1	12476	RCVR00109	Winkel-Einschraubstutzen, 12 mm	elbow, 90 degree, 12mm		
0014	1	11137	VTRS00068	Scheibe, Unterleg-, 21 x 38 x 3 mm, PVC	washer, 21 x 38 x 3 mm, PVC		
0015	1	01565	MEVR01906	Mutter, Gegen-, 1/2"	lock nut, 1/2"		

BUERSTENKOPF/BRUSHHEAD

BLATT/PAGE: 09

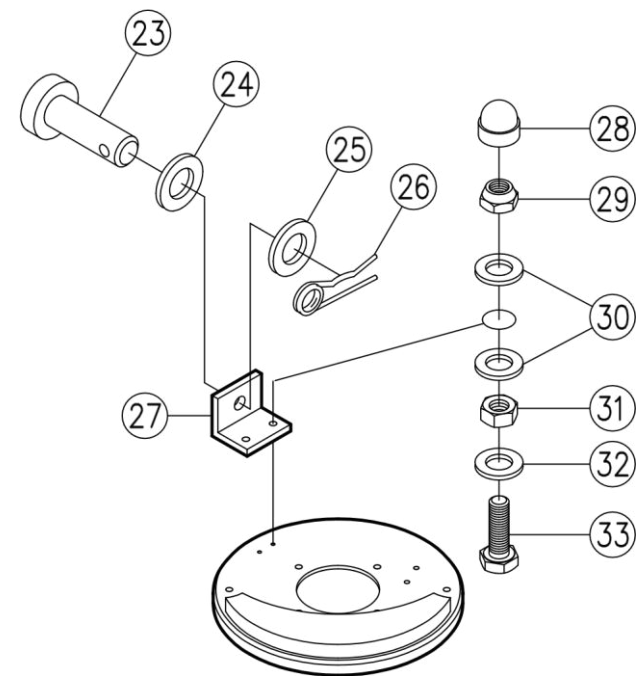
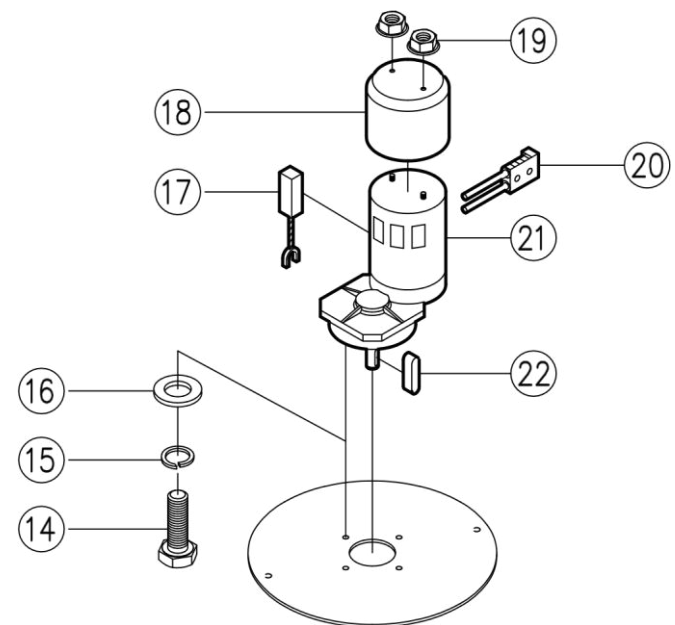
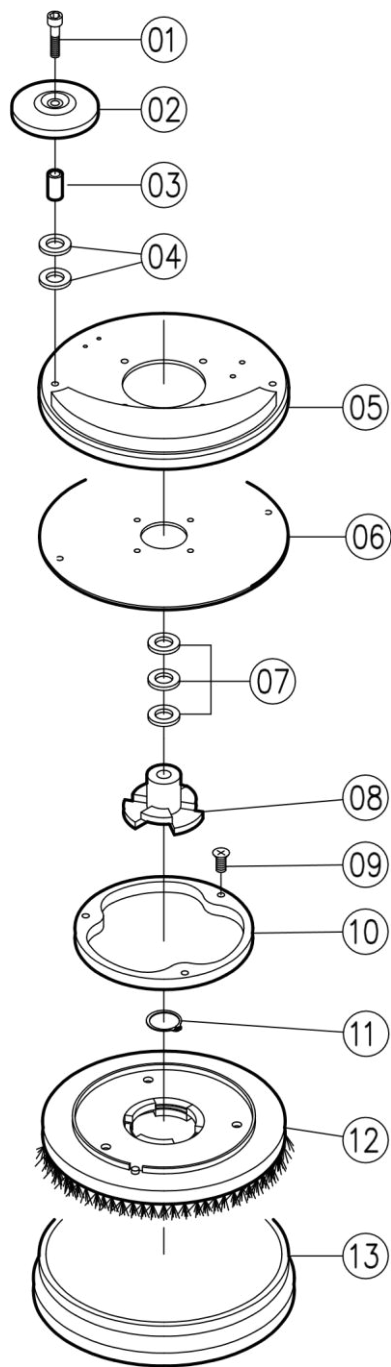

Buerstenkopf-Brush head

Position	Menge	Artikel-Nr.	IPC	Bezeichnung	Description	bis / up to	ab / from
0001	2	05138	VTVT01124	Schraube, Zylinderkopf-, M 10 x 35	slotted head screw, M 10 x 35		
0002	2	12370	RTRT00049	Ablenkrolle	guide roller		
0003	2	12469	LAFN01316	Buchse, 15/2 x 5 x 17,2mm, M 10	spacer sleeve, 15/2 x 5 x 17,2mm, M 10		
0004	4	05115	VTRS00509	Scheibe, Unterleg-, M 20	washer, M 20		
0005	1	03936	MPVR01034	Bürstenkopfronde, 31 B 50	cover for brush head, 31 B 50		
0006	1	22260	LAFN01467	Verstärkungsplatte, Bürstenkopfronde, 31B	reinforcing plate for brush head, 31 B		
0007	3	05511	VTRS00061	Paßscheibe, 18 x 25 x 0,1 mm	coach body disc, 18 x 25 x 0,1 mm		
0008	1	13926	MFVR00031	Bajonettkupplung, 18 mm	bajonett coupling, 18 mm		
0009	1	05436	VTVT00180	Schraube, Selbstschneidend, M 3 x 25	self tapping screw, M 3 x 25		
0010	1	13256	GUVR00031	Wasserleitring, beidseitig	water guiding ring		
0011	1	05195	VTAE00017	Sprengring, 17 mm	circlip, 17 mm		
0012	1	19265		Bürste, PPN 0,5, 460 mm	brush, ppn 0,5, 460 mm		
0013	1	41555	PMLA00138	Spritzgummi für Bürstenkopf 31 B 50	splash skirt for brush head 31 B 50		
0014	4	05012	VTVT00444	Schraube, Sechskant-, M 6 x 20	hexagonal screw, M 6 x 20		
0015	4	05131	VTRS01079	Federring, M 6	spring washer, M 6		
0016	4	05119	VTRS00041	Scheibe, Unterleg-, M 6	washer, M 6		
0017	1	14088	MOCC00058	Kohlebürsten für Bürstenmotor	carbon brush for brush motor		
0018	1	03791	MPVR01009	Abdeckkappe, für Bürstenmotor	cover for brush motor		
0019	2	05218	VTDD86633	Mutter, Sechskant-, M 6	hexagonal nut, M 6		
0020	1	01081	MEVR00152	Stecker, Bürstenmotor, 50 A, schwarz	plug for brush motor, 50 A, black		
0021	1	13887	MOCC00050	Motor, Bürsten-, 24V/600W	brush motor, 24V/600W		
0022	1	01676	VTVR21944	Passfeder, 6 x 6 x 30 mm	key, 6 x 6 x 30 mm		
0023	2	01787	LAFN01253	Bolzen mit Kopf, 12 x 40 mm	bolt with head, 12 x 40 mm		
0024	2	05126	VTRS00506	Scheibe, Unterleg-, M 12	washer, M 12		
0025	2	05126	VTRS00506	Scheibe, Unterleg-, M 12	washer, M 12		
0026	2	01677	VTVR00061	Federstecker, 3,2 mm	spring clip, 3,2 mm		

0027	2	41539	LAFN01543	Winkel, Bürstenkopf, 31 B	bracket for brush head, 31 B		
0028	4	75135	MPVR01575	Abdeckkappe, M 8	cover for srew, M 8		
0029	4	05220	VTDD86484	Mutter, Sechskant-, selbstsichernd, M 8	hexagonal nut, self sealing, M 8		
0030	8	05118	VTRS00503	Scheibe, Unterleg-, M 8	washer, M 8		
0031	2	05094	VTDD10776	Mutter, Sechskant-, M 8	hexagonal nut, M 8		
0032	4	05118	VTRS00503	Scheibe, Unterleg-, M 8	washer, M 8		
0033	4	05250	VTVT00449	Schraube, Sechskant-, M 8 x 35	hexagonal screw, M 8 x 35		

SAUGFUSS/SQUEEGEE

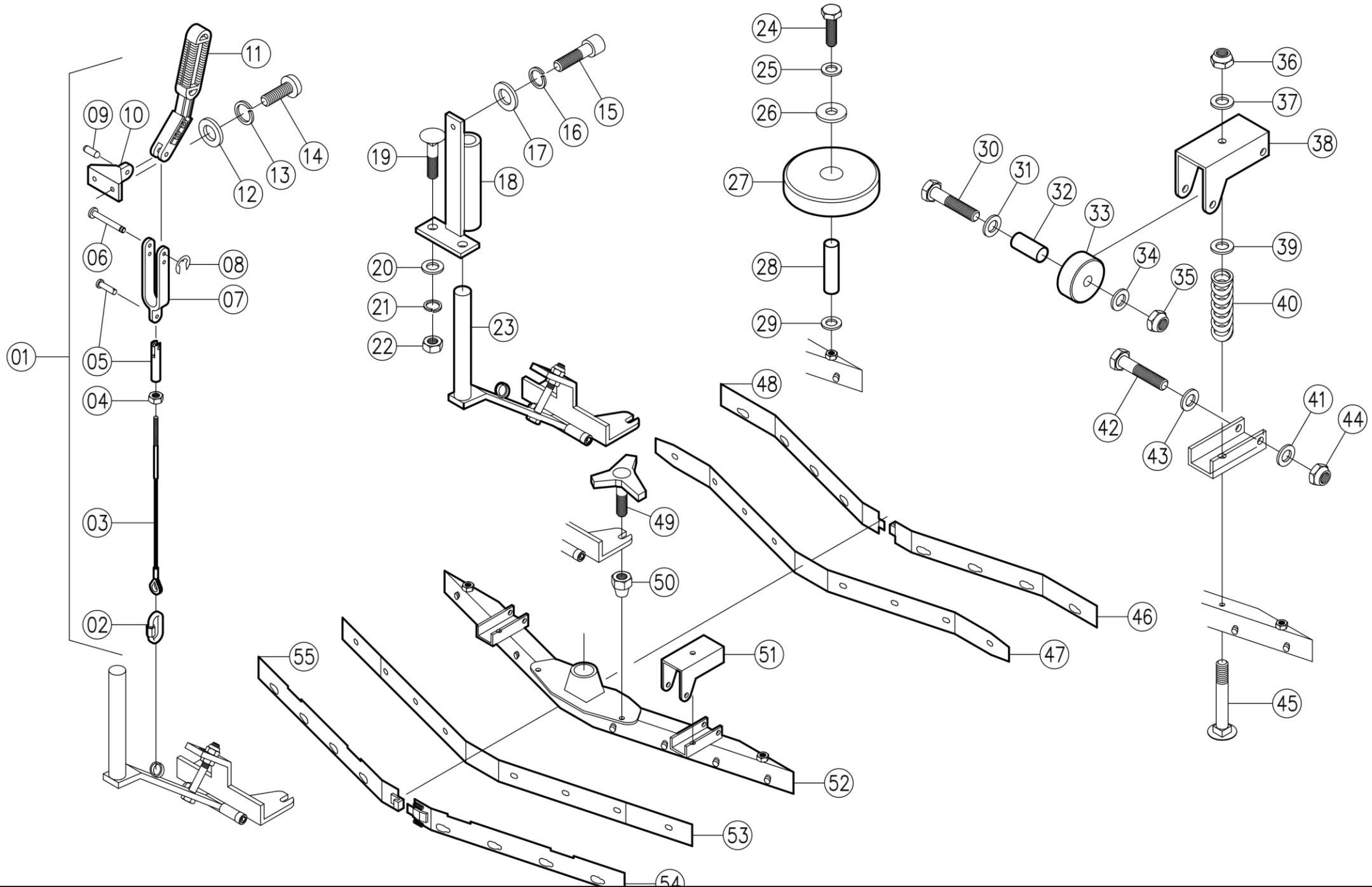

Saugfuss-Squeegee PMVR02023

Position	Menge	Artikel-Nr.	IPC	Bezeichnung	Description	bis / up to	ab / from
0001	1	41007	PMVR00464	Saugfussheber, komplett	squeegee lift, complete		
0002	1	12226	VTVR00082	Schäkel, 5 mm	eye ring, open, 5 mm		
0003	1	13150	CMCV00069	Drahtseil, 250 mm	wire rope, 250 mm		
0004	1	75154	VTDD09556	Mutter, Sechskant, M 3	hexagonal screw, M 3		
0005	1	12839	CMCV00068	Gabelterminal, 3 mm	two-way beeches piece for wire rope, 3mm		
0006	1	13400	LAFN01335	Drehstift, 40 x 5 mm	rotary pin, 40 x 5 mm		
0007	1	13390	CMCV00070	Zugstange, schwarz	pull rod, black		
0008	1	05471	VTRS00057	Sicherungsscheibe, 5 mm	shaft protection, 5 mm		
0009	1	05472	MEVR00173	Stift, Zylinder-, 5 x 18 mm	cylindrical pin, 5 x 18 mm		
0010	1	13391	MPVR01089	Winkel für Saugfussheber	angle for sqeegee lift		
0011	1	13389	MPVR01088	Saugfusshebergriff	handle for squeegee lift		
0012	2	05119	VTRS00041	Scheibe, Unterleg-, M 6	washer, M 6		
0013	2	05131	VTRS01079	Federring, M 6	spring washer, M 6		
0014	2	75090	VTVT00262	Schraube, Zylinderkopf-, M 6 x 20	allen cap screw, M 6 x 20		
0015	1	75013	VTVT00229	Schraube, Sechskant-, M 8 x 20	hexagonal screw, M 8 x 20		
0016	1	05136	VTRS01080	Federring, M 8	spring washer, M 8		
0017	1	05118	VTRS00503	Scheibe, Unterleg-, M 8	washer, M 8		
0018	1	22428	CUVR00032	Saugfusslager, 31 B	squeegee bearing, 31 B		
0019	2	75258	VTVT00326	Schraube, Schloss-, M 8 x 30	carriage bolt, M 8 x 30		
0020	2	75057	VTRS63243	Scheibe, Unterleg-, 8 x 24 mm	washer, 8 x 24 mm		
0021	2	05136	VTRS01080	Federring, M 8	spring washer, M 8		
0022	2	05094	VTDD10776	Mutter, Sechskant-, M 8	hexagonal nut, M 8		
0023	1		PMVR01242	Schwenkwinkel, Premium Linie	swivel angle, Premium Line		
0024	2	75018	VTVT00458	Schraube, Sechskant, M 10 x 35	hexagonal screw, M 10 x 35		
0025	2	05116	VTRS00505	Scheibe, Unterleg-, M 10	washer, M 10		
0026	2	05115	VTRS00509	Scheibe, Unterleg-, M 20	washer, M 20		
0027	2		MPVR02894	Ablenkrolle	guide roller		

0028	2		LAFN51074	Hülse für Ablenkrolle	sleeve for guide roller		
0029	2	05116	VTRS00505	Scheibe, Unterleg-, M 10	washer, M 10		
0030	2	05260	VTVT17344	Schraube, Sechskant, M 6 x 50	hexagonal screw, M 6 x 50		
0031	2	05119	VTRS00041	Scheibe, Unterleg-, M 6	washer, M 6		
0032	2		LAFN40138	Abstandshülse, für Stützrolle	sleeve for squeegee wheel		
0033	2		RTRT00379	Stützrolle am Saugfuss	squeegee wheel		
0034	2	05119	VTRS00041	Scheibe, Unterleg-, M 6	washer, M 6		
0035	2	05218	VTDD86633	Mutter, Sechskant-, selbstsichernd, M 6	hexagonal nut, selfsealing, M 6		
0036	2	05220	VTDD86484	Mutter, Sechskant-, selbstsichernd, M 8	hexagonal nut, selfsealing, M 8		
0037	2	05118	VTRS00503	Scheibe, Unterleg-, M 8	washer, M 8		

SAUGFUSS/SQUEEGEE

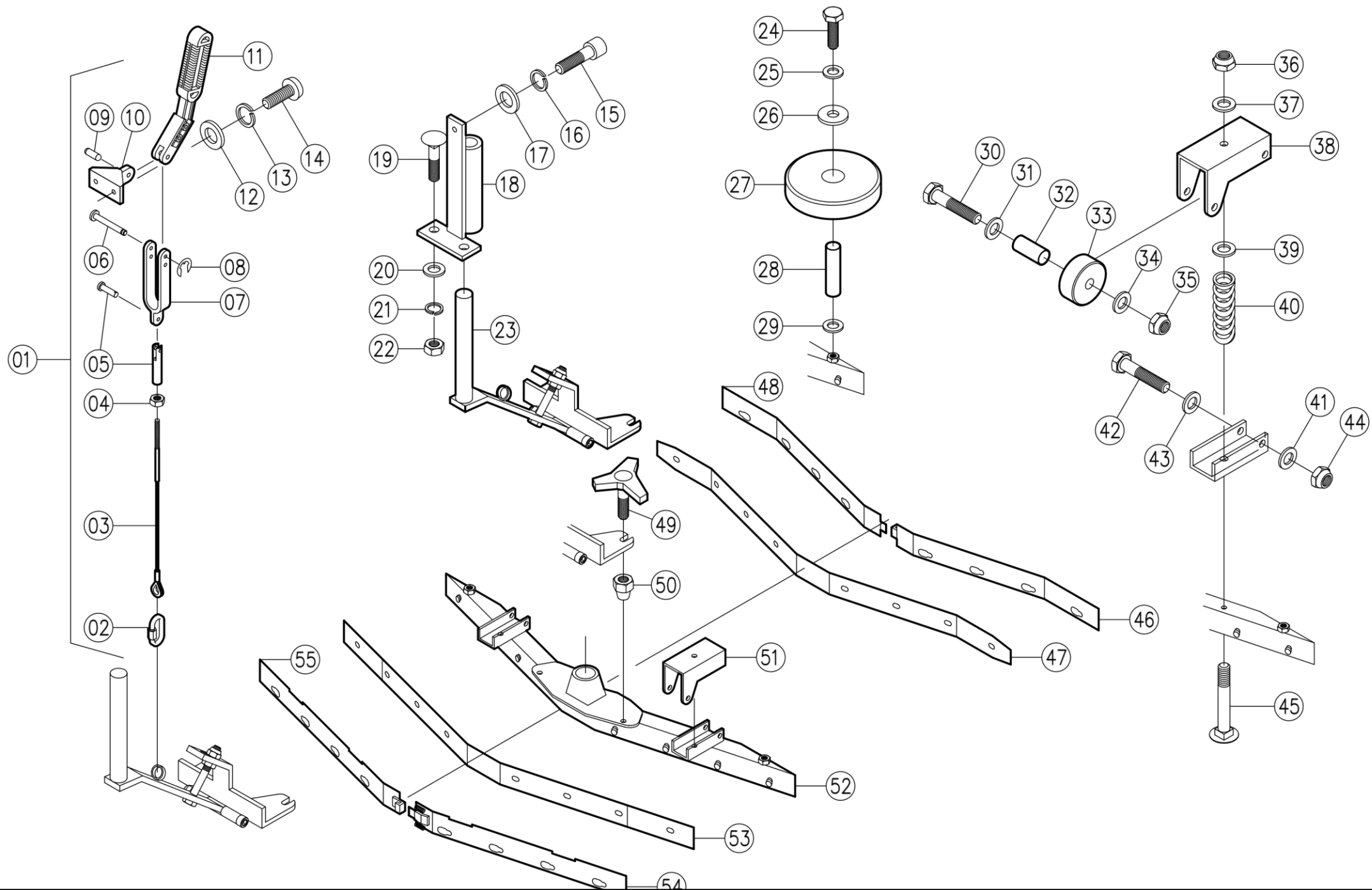

0038	2		LAFN05559	Halter für Stützrolle	support for squeegee wheel		
0039	2	05118	VTRS00503	Scheibe, Unterleg-, M 8	washer, M 8		
0040	2		MLML49422	Feder an Stützrolle	spring for squeegee wheel		
0041	2	05260	VTVT17344	Schraube, Sechskant, M 6 x 50	hexagonal screw, M 6 x 50		
0042	2	05119	VTRS00041	Scheibe, Unterleg-, M 6	washer, M 6		
0043	2	05119	VTRS00041	Scheibe, Unterleg-, M 6	washer, M 6		
0044	2	05218	VTDD86633	Mutter, Sechskant-, selbstsichernd, M 6	hexagonal nut, selfsealing, M 6		
0045	2	05004	VTVT01304	Schraube, Sechskant, M 8 x 40	hexagonal screw, M 8 x 40		
0046	1		LAFN51044	Klemmwinkel, vorne, rechts, SF 50/57cm	clamping angle,front,right,squeeg. 50/57cm		
0047	1		LAFN51045	Klemmwinkel, vorne, links, SF 50/57cm	clamping angle,front,left,squeeg. 50/57cm		
0048	1		MPVR45194	Sauglippe, vorne, SF 50/57cm	squeegee blade front, squeegee 50/57cm		
0049	2		MPVR05265	Sternschraube, M 8	Knob for squeegee fastener, M 8		
0050	2	16383	VTAE00074	Blindnietmutter, M 8	blind rivet nut, M 8		
0051	2		LAFN05559	Halter für Stützrolle	support for squeegee wheel		
0052	1		LAFN51069	Saugfusskörper, SF 50/57cm	squeegee body, for squeegee 50/57cm		
0053	1		MPVR45195	Sauglippe, hinten, SF 50/57cm	squeegee blade rear, squeegee 50/57cm		
0054	1		LAFN49284	Klemmwinkel, hinten, rechts, SF 50/57cm	clamping angle,rear,right,squeeg. 50/57cm		
0055	1		LAFN49285	Klemmwinkel, hinten, links, SF 50/57cm	clamping angle,rear,left,squeegee 50/57cm		

| | | | | | | | | | | |

|

Schaltplan/ Wiring diagram



31 B 50

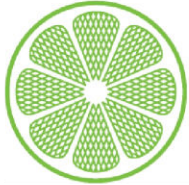

IPC Integrated Professional Cleaning

IPC Gansow

Änderungen/ Modification	ab Maschinennr. / from Machine no.	Datum/ Date

Name	Datum/ Date
gez.: E. Müller	04.03.2011
gepr.:	
www.gansow.de	info@gansow.de

Projekt/ project

31 B 50

Blatt/ Page

1

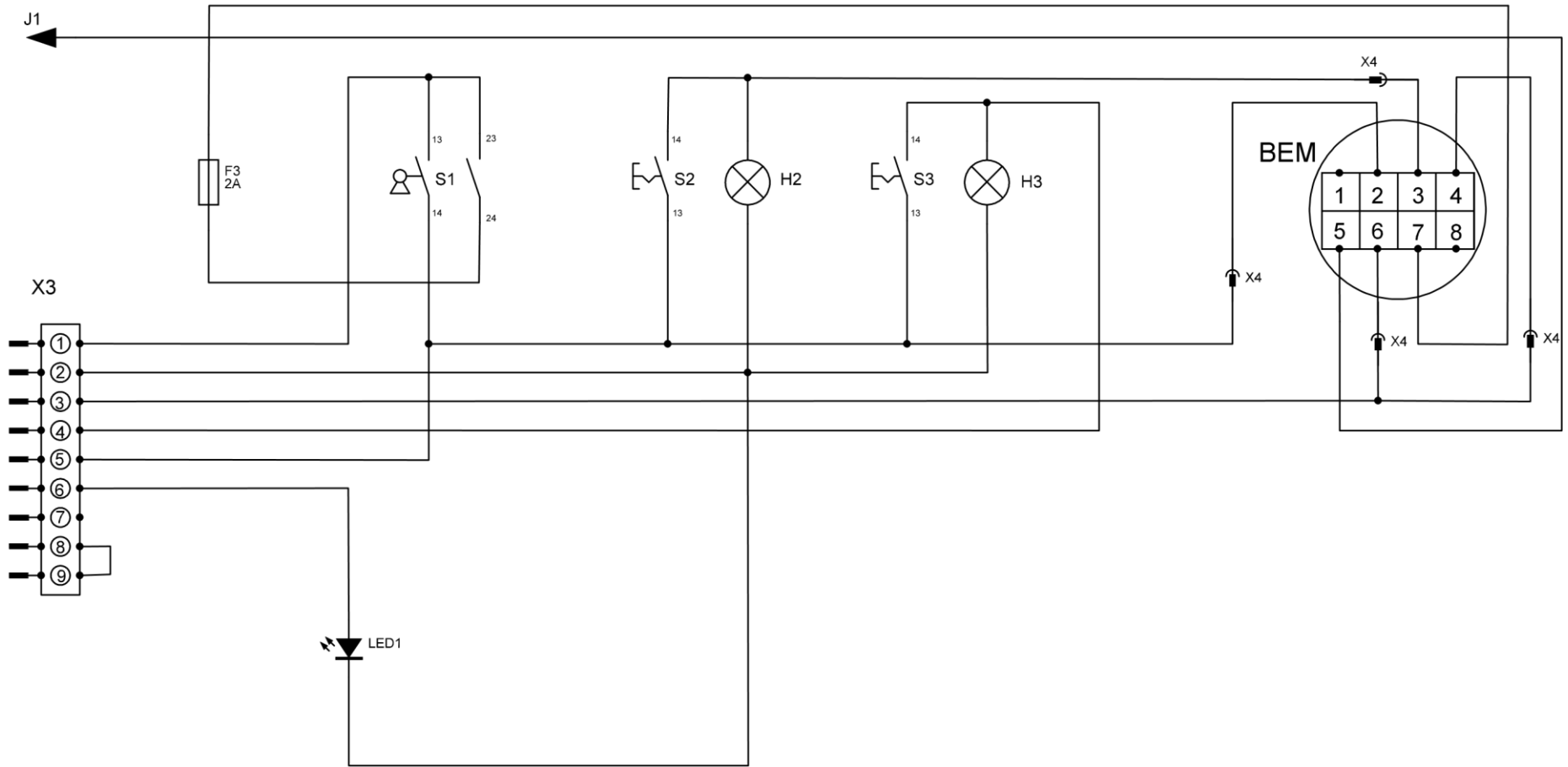

Materialliste/ List of components

Nr.:	Anz.	Name	Beschreibung	Bezug	Art. Nr.	Name	Description
Pos.	Qty.			Refer.	Part Code		
1	1	Batteriekapazitätsüberwachung	Bürstenmotorabschaltung	BEM	16278	Battery discharge indicator	Switching off brush motor
2	1	Batterie		Batt.		Battery	
3	1	Freilaufdiode	Freilaufdiode	D1	06088	Diode	Free wheeling diode
4	1	Freilaufdiode	Freilaufdiode	D2	06088	Diode	Free wheeling diode
5	1	Freilaufdiode	Freilaufdiode	D3		Diode	Free wheeling diode
6	2	Elektroden	Schmutzwasserdetektor	EL1		Probes	Foam/ dirty water detector
7	1	Polsicherung 75A	Hauptsicherung Batterie	F1	06918	Pole fuse 75A	Main fuse, battery
8	1	Schmelzsicherung 2A	BEM	F2	70164	Fuse 2A	BEM
9	1	Schmelzsicherung 7,5A	Steuersicherung	F3	70241	Fuse 7,5A	Control fuse
10	1	Sicherungsautomat 25A	Bürstenmotor	F4	14643	Circuit breaker 25A	Brushmotor
11	1	Sicherungsautomat 25A	Saugmotor	F5	14643	Circuit breaker 25A	Vacuum motor
12	1	Meldeleuchte	Bürsten Ein/ Aus	H2	06345	Pilot lamp	Bush on/ off
13	1	Meldeleuchte	Saugmotor Ein/ Aus	H3	06345	Pilot lamp	Vacuum on/ off
14	1	Schütz/ 124A	Bürstenmotor	K1	06328	Contactorf/ 124A	Brushmotor
15	1	Schütz/ 124A	Saugmotor	K2	06328	Contactorf/ 124A	Vacuum motor
16	1	Bürstenmotor	Bürstenmotor 24V	M1	13887	Brush motor	Brush motor 24V
17	1	Saugmotor	Saugmotor 24V	M2	12757	Vacuum motor	Vacuum motor 24V
18	1	LED	Reinwasser leer	LED1	11738	LED	Solution tank empty
19	1	Schaumabschaltung	Abschaltung des Saugmotors	SAS	14254	Foamcontrol	Switch off vacuum motor
20	1	Schlüsselschalter	Maschine An/ Aus	S1	KTRI15039	Key switch	Machine on/ off
21	1	Schalter Bürste	Bürste An/ Aus	S2	KTRI15038	Switch brush	Brush on/ off
22	1	Schalter Saugmotor	Absaugung An/ Aus	S3	KTRI15040	Switch vacuum motor	Vacuum on/ off
23	1	Schwimmerschalter	Reinwasser leer	S4	MECI00516	Float switch	Solutiontank empty
24	1	Mikroschalter Batteriestecker	Maschinen Stop bei Laderverbindung	S5	16433	Microswitch batterieplug	Machine stop during charging
25	1	Batteriestecker	50A	X1	11333	Batterieplug	50A
26	1	Klemmleiste		X2		Terminal block	
27	1	Kupplung/ Stecker	Steckverbinder	X3	31245, 31246	Connector/ plug	Pin/ socket connector
28	1	Kupplung/ Stecker	Steckverbinder BEM	X4		Connector/ plug	Pin/ socket connector BEM
29	1	Kupplung/ Stecker	Steckverbinder Schwimmerschalter S4	X5		Connector/ plug	connector float switch S4
30	1	Kupplung/ Stecker	Steckverbinder Bürstenmotor M1	X6		Connector/ plug	connector brush motor M1
31	1	Kupplung/ Stecker	Steckverbinder Saugmotor M2	X7		Connector/ plug	connector vacuum motor M2
32	1	Magnetventil		YQ1	13144	Solenoid valve	
33							
34							
35							