

IPC Integrated Professional Cleaning



# IPC Gansow



## Service Manual

for scrubber drier  
61 BF 57

***English***

IP Gansow GmbH  
Dreherstraße 9  
59425 Unna  
[www.gansow.de](http://www.gansow.de)  
[kundendienst@gansow.de](mailto:kundendienst@gansow.de)  
Tel.: 0049 (0)2303 2580-0





**IPC Integrated Professional Cleaning**

**IPC Gansow**



**Translation of the  
Original operating instructions  
for scrubber drier**

***models 31 - 41 - 61 - 71 - 91 - 101 - 121 - 131 B / BF***

IP Gansow GmbH  
Dreherstraße 9  
D 59425 Unna  
Tel.: 0049 2303 2580-0  
[info@gansow.de](mailto:info@gansow.de)  
[www.gansow.de](http://www.gansow.de)

## **INDEX:**

<b>1. IMPORTANT WARNINGS.....</b>	<b>3</b>
<b>2. INSTRUCTIONS BEFORE OPERATING.....</b>	<b>5</b>
<b>3. PRACTICAL GUIDE FOR THE OPERATOR.....</b>	<b>6</b>
<b>4. INSTRUCTIONS.....</b>	<b>8</b>
<b>5. TROUBLESHOOTING.....</b>	<b>12</b>
<b>6. CLEANING AND MAINTENANCE.....</b>	<b>15</b>
<b>7. OPTIONAL ACCESSORIES.....</b>	<b>16</b>
<b>8. CE CONFORMITY DECLARATION.....</b>	<b>17</b>
<b>9. TECHNICAL SPECIFICATION.....</b>	<b>22</b>
<b>SPECIAL INFORMATION FOR</b>	
<b>10. USING THE BATTERIES AND CHARGER.....</b>	<b>23</b>
<b>CONTROL AND MAINTENANCE</b>	
<b>11. OPERATIONS.....</b>	<b>27</b>

## 1. IMPORTANT WARNINGS:

- 1.1. **IMPORTANT!** This appliance is not suitable for removing dusts hazardous to health.
- 1.2. **IMPORTANT!** This appliance is not suitable for washing carpet or textile floors or wood floors not treated with non-absorbent resin.
- 1.3. This appliance is not approved for use on public roads or highways.
- 1.4. This appliance may only be used by personnel fully trained in its correct and appropriate use.
- 1.5. In order to prevent unauthorised use of the machine always remove the key from the key switch before leaving the appliance unattended.
- 1.6. Lower the brushes before leaving the machine unattended to prevent accidental movement.
- 1.7. When using the machine the operator should take care not to endanger any third persons, particularly children.
- 1.8. The appliance may not be used on slopes of greater than 2%.
- 1.9. We expressly draw your attention to the fact that original parts and accessories not supplied directly by Gansow have not been tested or authorised by Gansow.  
The installation and/or use of such items may therefore adversely affect the efficiency and characteristics of your floor cleaning machine, jeopardising its active and passive safety.  
The manufacturer declines all liability for damage occurring as a result of the use of non-original parts or accessories.
- 1.10. Before any cleaning or servicing work is carried out on the machine, the following precautions must be taken:
  - unplug the plug from the charger from the charger socket;
  - remove the key from the control panel.

## ATTENTION !

***Before changing the main fuse, disconnect the battery cables from the respective terminals (danger of short circuit).***

- 1.11. Under no circumstances may the charger leads (connecting the charger to the machine) supplied be modified.
- 1.12. All electrical functions of the machine are interrupted immediately as soon as the plug is plugged into the charger socket.
- 1.13. This appliance may be used with the brushes provided by the producer only.

## ATTENTION !

***The safety of the appliance will be jeopardised by the use of other brushes.***

- 1.14. **\*IMPORTANT - battery gas is highly explosive;**
  - avoid sparks or open flames close to the batteries!To avoid the build-up of gas inside the machine, the tank and tank lid must remain in the raised position throughout charging. The caps of all battery cells must also be unscrewed and/or removed (not necessary in the case of gel batteries).
- 1.15. **\*IMPORTANT - battery acid is corrosive!**

When topping up with distilled water make sure the level of liquid is the same in all the battery cells. Dry cells shorten battery life and may cause irreparable damage to the entire battery (not relevant to gel batteries).
- 1.16. **IMPORTANT!** Rooms where batteries are being charged should always be well ventilated.

*\* Not relevant to maintenance free gel batteries*

## 2. INSTRUCTIONS BEFORE OPERATING:

- 2.1. Before operating a battery-powered machine, please read all the following instructions and the instructions for use of the charger (if purchased).
- 2.2. Note that the batteries deliver maximum power only after eight to ten charging cycles. During this period, the machine should not therefore be used for excessively heavy cleaning.
- 2.3. To provide your battery with even greater protection, the machine is equipped with a charge indicator and hour counter.

By means of variously coloured LEDs (seven yellow and one red), this provides a constant indication of the charge and automatically shuts the brush motors down when the charge drops below the safety level.

The **LEDs** indicate the following stages:

**YELLOW ON:** batteries within the charge limit

**YELLOW FLASHING** 15 seconds of running time remain before the brush motors shut down.

**RED ON:** the battery is flat and the brushes are blocked. You should immediately go to the charging area to avoid damaging the batteries.

The transition of one LED to another with a delay of just 15 seconds ensures a prompt response in the event of flat batteries to avoid discharging them further and therefore irreparably reducing their working life.

- 2.4. **IMPORTANT!** The machine must not under any circumstances be started up with the front and top lids raised.

### 3. PRACTICAL GUIDE FOR THE OPERATOR:

#### 3.1. \*IMPORTANT - Seal the battery cells by screwing on the caps.

*\* Not relevant to maintenance free gel batteries*

- 3.2. After turning the charger off, unplug the connection lead from the charger from the battery socket to power the machine.
- 3.3. Lift the top lid and use a hose or bucket to fill the clean water tank (on the left) with cold water up to a maximum of 3 cm from the top of the tank (the water should preferably be cold and in any case never hotter than 60°C).

**IMPORTANT!** Use low foam detergent as excessive foam could jeopardise the efficiency and function of the machine.

Close the top lid, lifting slightly on the hinge side to make sure it fits perfectly to the tank.

**IMPORTANT!** If the lid does not fit perfectly, there would be no vacuum at the squeegee and therefore no flow-back of liquid to the collection tank (on the right). If necessary, repeat the operation correctly.

Avoid resting heavy objects on the lid as this could warp it and prevent it from fitting perfectly to the tank.

- 3.4. Make sure the cap of the dirty water tank (on the right) drain hose is correctly in place. Perfect closure of the cap is essential to obtain a vacuum in the collection tank and therefore maximum suction power.
- 3.5. Turn the key switch clockwise to start the machine.
- 3.6. Light pressure and a slight sideways movement of the pedal release the brushes which are lowered in contact with the ground.
- 3.7. To activate brush rotation, press the corresponding button on the left side of the control panel.

**MACHINES WITH DIAPHRAGM:** *Pressing this button opens the water solenoid valve and turns the water pump on.  
Turn the knob on the control panel clockwise to adjust the quantity of water to the brushes (from 0 to 7 litres).*



**MACHINES WITHOUT DIAPHRAGM:** *Pressing this button opens the water solenoid valve.*

*To adjust the quantity of water to the brush in accordance with the dirt to be removed (more dirt=more solution), use the red lever at the bottom on the operator's right. When the lever is horizontal, the cock is fully open, when vertical it is completely closed.*

- 3.8.** Lower the squeegee to the ground, using the control lever in front of the operator under the handle.
- 3.9.** Turn on suction to convey the dirty water to the collection tank, using the button marked with a fan on the right of the control panel.

## 4. INSTRUCTIONS:

### 4.1. SERIES "B" MODELS WITHOUT DRIVE:

The appliance is equipped with a patented drive system - as the brush rotates in contact with the ground, it draws the whole machine along at the correct working speed.

By pushing slightly, the drive speed can be increased as required. Holding it back slows it down.

### **SERIES "BF" MODELS WITH DRIVE:**

Push the drive lever gradually forwards to advance the machine at the required speed. The maximum possible speed is 5.5 km/h.

On curves, adjust speed by moving the drive lever backwards. When the lever is released completely, the drive motor stops automatically.

## ATTENTION!

***The drive unit is fitted with a crush prevention device consisting of a square red button at the centre of the handle which changes the direction of movement if touched while the appliance is in reverse. This prevents the operator being crushed in the event of incorrect manoeuvres.***

### 4.2. Clean in parallel strips overlapping by 3 to 4 cm.

Rollers on the ends of the squeegee act as bumpers and also enable you to clean at a tangent to the edges. The extreme manoeuvrability of the squeegee which can be swung freely and widely to both sides enables you to clean around any obstacle. The squeegee then returns to the central position when the obstacle or curve has been passed. When consigning the machine or during a demonstration, our service technician can advise you on the best way of cleaning your own particular floor surface.

### 4.3. By means of a vacuum created inside the collection tank, the used water and the dirt are completely absorbed and conveyed to the dirty water tank.

To prevent dirty water or foam damaging the vacuum motor, the collection tank is protected by two sensors (*electrodes*) which shut

the machine down when the tank is full (*they also detect the level of any foam present*).

- 4.4. After finishing the work or when the solution in the tank is used up (indicated with a red flashing light on the switch board), stop brush rotation by pressing the corresponding button. This also stops the flow of water. Raise the head using the pedal.
- 4.5. To collect the remaining dirt, continue for a further 3-4 metres with suction activated and the squeegee lowered, than turn both functions off by pressing the suction button and raising the squeegee lever. This empties all water left in the circuit into the collection tank.

## **IMPORTANT !**

***After you have finished cleaning, you are recommended to raise the tank lid and turn the suction motor on again for a few minutes. The dry air sucked in will evaporate any remaining moisture, extending the working life of the motor.***

- 4.6. Empty the collection tank into a container or drain using the black drain hose and proceeding as follows:
  - detach the hose from the control panel;
  - **keeping the hose raised above the level of the tank at all times**, remove the cap;
  - lower the hose gradually towards the container.
- 4.7. **IMPORTANT!** After each cleaning session, you are recommended to drain the dirty water and rinse the tank to avoid unpleasant smells or the formation of harmful germs. **To make this operation faster, simpler and more effective, the appliance is fitted with an exclusive system:**
  - the tank tilts backwards, after raising the lid, lift the tank until it rests on the chassis (empty before tilting);
  - after removing the cap, lower the drain hose to allow the water to run off rapidly;
  - wash the collection tank with running water;
  - leave the tank tilted until the next time you use the machine.

The appliance has been designed to facilitate thorough maintenance. A little attention improves the efficiency of your appliance and extends the already long working life.

- 4.8. When parking the machine, you are recommended to lower the brush head to anchor it to the ground.
- 4.9. The machine has a rapid brush replacement system:
- 1- *turn the key to the off position (anticlockwise as far as it will go),*
  - 2- use the pedal to lift the brush head,
  - 3- *hold the brush with both hands and turn it sharply in the normal direction of rotation. In the case of heads with two motors, the direction of rotation is always towards the centre of the head. Hold the bayonet coupling firmly in position and release the brush.*
  - 4- remove the brush and position the replacement in the centre of the housing, precisely under the bayonet coupling,
  - 5- *use the pedal to raise the brush head,*
  - 6- switch the appliance on and activate brush rotation for a few moments, then turn off again,
  - 7- *finally, raise the brush head and make sure the brush is correctly fitted. If necessary, repeat operations 1 to 6.*
- 4.10. The key switch should be turned off before recharging the batteries.
- 4.11. In order to avoid any build-up of gas inside the machine, the tank (previously emptied) covering the batteries must be raised and remain in that position throughout charging. Similarly, the caps of all battery cells must also be unscrewed and/or removed (not necessary in the case of maintenance-free gel batteries).



## PRECAUTIONS

***Battery gas is highly explosive. Avoid sparks and open flames near the batteries.***

When topping up with distilled water make sure the level of liquid is the same in all the battery cells. Dry cells shorten battery life and may cause irreparable damage to the entire battery (*not relevant to maintenance-free gel batteries*).

## **ATTENTION!**

*If the battery is damaged, the acid is highly corrosive!*

**4.12. IMPORTANT!** Rooms where batteries are being charged should always be well ventilated.

Before using battery-powered models, read carefully the instructions on use and maintenance of the machine, batteries and charger; procedures and precautions to be observed while charging batteries and connecting the charger and inspection and maintenance of batteries and maintenance schedules.

## 5. TROUBLESHOOTING:

### 5.1. *No water is delivered, check that:*

- the brush is moving,
- if necessary, activate the brush by using the button on the left of the control panel,
- there is water in the tank and the level is above the filter (the red LED on the switch board is flashing),
- if necessary, top up and add detergent,
- the clean water filter is not clogged,
- if necessary, remove and clean with air from the outside inwards,
- the water solenoid valve is operating correctly,
- if necessary, remove and clean,
- the water cock is open (lever horizontal = fully open, lever vertical = fully closed),
- the knob on the control panel (diaphragm machines only) is not on zero.

### 5.2. *The water flow does not stop:*

- close the water cock, then remove the solenoid valve and thoroughly clean the inside, including the closure spring housing,
- open the cock again and check it works,
- replace the valve if necessary.

### 5.3. *The suction motor does not start:*

- reset by using the key switch to turn the appliance off then on again,
- clean the collection tank around the sensor electrodes and the electrodes themselves.

## ATTENTION!

***Do not move the electrodes from their original position. Make sure they are not already out of position. By modifying the distance between them, or between the electrodes and the side of the tank, the power cut-off mechanism may be activated by mistake. Contact the Gansow Distributor Technical Assistance Service if necessary.***

- check the main fuse.
- check the charge of the batteries and if necessary, charge.

#### **5.4. *Water is not sucked up, although the motor is operating;***

- make sure the cap is correctly in place on the drain hose.
- make sure the suction hose between the squeegee and the dirty water tank is not blocked. If necessary unblock and fix the hose well to both connecting pieces.
- make sure the top lid is correctly in place on the tank, raise and lower as described in point 3.3,
- check the batteries are not flat.

#### **5.5. *The squeegee leaves wet marks or stripes:***

- clean the blades of the squeegee and remove any trapped grit or paper,
- check the wear of the squeegee blades and if necessary, turn or replace,
- **PARABOLIC SQUEEGEE:** make sure that when moving forwards with suction on, the squeegee is perfectly horizontal. If necessary, adjust the central nuts.
- carry out the checks described in point 5.4.

## **IMPORTANT !**

***When dealing with large amounts of fluff, this may accumulate under the rear squeegee blade causing leakage and therefore preventing perfect drying. If this occurs, the squeegee should be raised while at the same time moving the machine backwards to pick up the dirt left on the ground, proceeding in a diagonal direction.***

#### **5.6. *The squeegee sticks to the floor due to strong suction:***

- check the state of the front blade and in particular the inlet slits. If obstructed or worn, clean or enlarge them slightly, or cut one to three additional slits until the squeegee functions correctly,
- turn round or replace excessively worn squeegee blades. They can be reversed to extend the working life,
- **STRAIGHT SQUEEGEE:** adjust pressure on the ground using the screw on the mobile support, tightening lightens the pressure, unscrewing increases pressure.
- **PARABOLIC SQUEEGEE:** adjust pressure on the ground by tightening the adjustment nuts above the levelling wheels on the back of the squeegee.

**5.7. *The brush motor shuts down:***

- the automatic battery protection device has tripped. Stop working and recharge the batteries immediately.

**5.8. *The dirty water does not drain out through the hose:***

- make sure the tank is not blocked near the drain outlet.
- remove any blockages in the drain hose itself.

**5.9. *The machine leaves a smeary mark:***

- no water flow,
- *no solution in the tank (fill the tank), or solution tank filter dirty (clean filter),*
- check the brush feed pipe which could be blocked,
- *open the water cock if closed.*
- carry out the additional checks described in point 5.1.

**5.10. *The machine does not move forward or moves forward too slowly (BF SERIES MODELS WITH DRIVE ONLY)***

- check and remove any oxidation on the battery terminals, then tighten,
- the squeegee is stuck to the ground by excessive suction. See point 5.6.
- the batteries are flat, stop work and recharge.



## 6. SERVICE AND MAINTENANCE:

- 6.1. Before any servicing or maintenance work is carried out on the machine and before any parts are replaced:
  - drain both tanks completely,
  - unplug the plug from the charger from the charger socket,
  - turn off the key switch.
- 6.2. The electrodes in the dirty water tank should always be kept clean and in their original position. By modifying the distance between them, or between the electrodes and the tank, the power cut-off mechanism may not activate correctly.
- 6.3. Clean the dirty water tank thoroughly and regularly to prevent the formation of unpleasant odours and bacteria. Tilt the tank to facilitate cleaning.
- 6.4. The tank lid should always be left open between cleaning sessions to enable the internal surface to dry out. Never place heavy objects on the top lid as this could warp it.
- 6.5. After each cleaning session, clean the outside of the machine to remove any chemical residues which could accelerate wear and affect the appearance of the materials.
- 6.6. The filter in the clean water tank should be cleaned regularly twice a week.
- 6.7. Check the state of the squeegee blades regularly and if necessary turn them over or replace them. See also sections 5.5. and 5.6.
- 6.8. Perform battery maintenance regularly to maintain their efficiency and extend their working life. They are expensive and should be kept in good condition.
- 6.9. The outlet slits on the suction motor should be checked and cleaned regularly, especially where there is a considerable amount of fluff in the atmosphere.
- 6.10. A general control by authorised Gansow personnel is recommended at least once every six months.

## 7. OPTIONAL ACCESSORIES:

7.1. Depending on the type of floor and dirt, you may want to use brushes other than those supplied as standard.

The following are available from your Gansow Distributor:

- Black soft and PES brushes for delicate floors (gyms, sealed wood, etc);
- in polycarbonate of various hardnesses for a more energetic and deep treatment.

7.2. As an alternative to the brushes, you can use a pad, available in three versions with different colours:

- **black** = abrasive
- **red/green/purple** = medium hard
- **brown/yellow/white** = soft.

The brush does not need to be removed to use the pad, which can be fitted directly to the brush itself. Alternatively, a special pad holder can be provided.

## 8. TECHNICAL SPECIFICATION:

		<b>31 B 46/50</b>	<b>41 B/BF 53/57</b>	<b>61 B/BF 53/57</b>
<b>Cleaning width</b>	<b>mm</b>	460/500	530/570	530/570
<b>Squeegee width</b>	<b>mm</b>	870	870	870
<b>Capacity per hour theor.</b>	<b>m<sup>2</sup>/h</b>	1840	2120/2930	2120/2930
<b>Maximum speed</b>	<b>km/h</b>	4	4/5,5	4/5,5
<b>Number of brushes</b>	<b>no.</b>	1	1	1
<b>Brush diameter</b>	<b>mm</b>	460	533	533
<b>Max. brush pressure</b>	<b>kg</b>	24	31.5	31.5
<b>Pressure of brush head on the ground</b>	<b>g/cm<sup>2</sup></b>	110	109	109
<b>Brush rotation speed</b>	<b>rpm</b>	180	200	200
<b>Brush motor power</b>	<b>W</b>	600	650	650
<b>Drive</b>	<b>-</b>	Mechanical	<b>B : MECHANICAL BF : ELECTRONIC</b>	<b>B : MECHANICAL BF : ELECTRONIC</b>
<b>Nominal drive motor power</b>	<b>W</b>	/	<b>B : / BF : 200</b>	<b>B : / BF : 200</b>
<b>Suction motor power</b>	<b>W</b>	350	410	550
<b>Sound pressure</b>	<b>dB(A)</b>	83	83	83
<b>Solution tank</b>	<b>l</b>	26	40	62
<b>Collection tank</b>	<b>l</b>	26	40	62
<b>Diaphragm</b>	<b>/</b>	-	-	Yes
<b>Drive wheel diameter</b>	<b>mm</b>	160	230	230
<b>Pivoting wheel diameter</b>	<b>mm</b>	125	125	125
<b>Net weight without batteries</b>	<b>kg</b>	100	<b>B : 129 BF : 142</b>	<b>B : 135 BF : 148</b>
<b>Number of batteries</b>	<b>no.</b>	2	2	2
<b>Voltage of batteries in series</b>	<b>V</b>	24	24	24
<b>Machine size</b>	<b>cm X/Y/Z</b>	124x51x95	128,5x60,5x108,5 143x60,5x108,5	128,5x60,5x113 143x60,5x113
<b>Total oscillation value</b>	<b>m/s<sup>2</sup></b>	<2,5	<2,5	<2,5

## TECHNICAL SPECIFICATION:

		<b>61 B/BF 65/68</b>	<b>71 BF 70/72</b>	<b>71 BF 85</b>
<b>Cleaning width</b>	<b>mm</b>	650/680	700/720	850
<b>Squeegee width</b>	<b>mm</b>	1000	1000	1150
<b>Capacity per hour theor.</b>	<b>m<sup>2</sup>/h</b>	2120/2930	3850	4675
<b>Maximum speed</b>	<b>km/h</b>	4/5,5	5,5	5,5
<b>Number of brushes</b>	<b>no.</b>	2	2	2
<b>Brush diameter</b>	<b>mm</b>	345	370	430
<b>Max. brush pressure</b>	<b>kg</b>	31,5	40	45
<b>Pressure of brush head on the ground</b>	<b>g/cm<sup>2</sup></b>	125	156	135
<b>Brush rotation speed</b>	<b>rpm</b>	180	180	180
<b>Brush motor power</b>	<b>W</b>	250	400	400
<b>Drive</b>	<b>-</b>	<b>B : MECHANICAL BF : ELECTRONIC</b>	ELECTRONIC	ELECTRONIC
<b>Nominal drive motor power</b>	<b>W</b>	<b>B : / BF : 200</b>	400	400
<b>Suction motor power</b>	<b>W</b>	550	550	550
<b>Sound pressure</b>	<b>dB(A)</b>	83	82	82
<b>Solution tank</b>	<b>l</b>	62	70	70
<b>Collection tank</b>	<b>l</b>	62	70	70
<b>Diaphragm</b>	<b>/</b>	Yes	-	-
<b>Drive wheel diameter</b>	<b>mm</b>	230	230	230
<b>Pivoting wheel diameter</b>	<b>mm</b>	125	160	160
<b>Net weight without batteries</b>	<b>kg</b>	<b>B : 137 BF : 150</b>	185	187
<b>Number of batteries</b>	<b>no.</b>	2	4	4
<b>Voltage of batteries in series</b>	<b>V</b>	24	24	24
<b>Machine size</b>	<b>cm X/Y/Z</b>	124x69x113 139x69x113	163x76x111	167x86x111
<b>Total oscillation value</b>	<b>m/s<sup>2</sup></b>	<2,5	<2,5	<2,5

**TECHNICAL SPECIFICATION:**

		<b>91 BF 70/72</b>	<b>91 BF 85</b>	<b>101 BF 70/72</b>
<b>Cleaning width</b>	<b>mm</b>	700/720	850	700/720
<b>Squeegee width</b>	<b>mm</b>	1000	1150	1000
<b>Capacity per hour theor.</b>	<b>m<sup>2</sup>/h</b>	3850	4675	3850
<b>Maximum speed</b>	<b>km/h</b>	5,5	5,5	5,5
<b>Number of brushes</b>	<b>no.</b>	2	2	2
<b>Brush diameter</b>	<b>mm</b>	370	430	370
<b>Max. brush pressure</b>	<b>kg</b>	40	45	40
<b>Pressure of brush head on the ground</b>	<b>g/cm<sup>2</sup></b>	156	135	156
<b>Brush rotation speed</b>	<b>rpm</b>	180	180	180
<b>Brush motor power</b>	<b>W</b>	400	400	400
<b>Drive</b>	<b>-</b>	ELECTRONIC	ELECTRONIC	ELECTRONIC
<b>Nominal drive motor power</b>	<b>W</b>	400	400	400
<b>Suction motor power</b>	<b>W</b>	550	550	550
<b>Sound pressure</b>	<b>dB(A)</b>	82	82	85
<b>Solution tank</b>	<b>l</b>	90	90	100
<b>Collection tank</b>	<b>l</b>	90	90	100
<b>Diaphragm</b>	<b>/</b>	Yes	Yes	Yes
<b>Drive wheel diameter</b>	<b>mm</b>	230	230	230
<b>Pivoting wheel diameter</b>	<b>mm</b>	125	125	160
<b>Net weight without batteries</b>	<b>kg</b>	169	171	179
<b>Number of batteries</b>	<b>no.</b>	4	4	4
<b>Voltage of batteries in series</b>	<b>V</b>	24	24	24
<b>Machine size</b>	<b>cm X/Y/Z</b>	139x76x113	139x86x113	163x76x115,5
<b>Total oscillation value</b>	<b>m/s<sup>2</sup></b>	<2,5	<2,5	<2,5

**TECHNICAL SPECIFICATION:**

		<b>101 BF 85</b>	<b>121 BF 70/72</b>	<b>121 BF 85</b>
<b>Cleaning width</b>	<b>mm</b>	850	700/720	850
<b>Squeegee width</b>	<b>mm</b>	1150	1000	1150
<b>Capacity per hour theor.</b>	<b>m<sup>2</sup>/h</b>	4675	3850	4675
<b>Maximum speed</b>	<b>km/h</b>	5,5	5,5	5,5
<b>Number of brushes</b>	<b>no.</b>	2	2	2
<b>Brush diameter</b>	<b>mm</b>	430	370	430
<b>Max. brush pressure</b>	<b>kg</b>	45	40	45
<b>Pressure of brush head on the ground</b>	<b>g/cm<sup>2</sup></b>	135	156	135
<b>Brush rotation speed</b>	<b>rpm</b>	180	180	180
<b>Brush motor power</b>	<b>W</b>	400	400	400
<b>Drive</b>	<b>-</b>	ELECTRONIC	ELECTRONIC	ELECTRONIC
<b>Nominal drive motor power</b>	<b>W</b>	400	400	400
<b>Suction motor power</b>	<b>W</b>	550	550	550
<b>Sound pressure</b>	<b>dB(A)</b>	85	82	82
<b>Solution tank</b>	<b>l</b>	100	120	120
<b>Collection tank</b>	<b>l</b>	100	120	120
<b>Diaphragm</b>	<b>/</b>	Yes	Yes	Yes
<b>Drive wheel diameter</b>	<b>mm</b>	230	230	230
<b>Pivoting wheel diameter</b>	<b>mm</b>	160	160	160
<b>Net weight without batteries</b>	<b>kg</b>	181	194	196
<b>Number of batteries</b>	<b>no.</b>	4	4	4
<b>Voltage of batteries in series</b>	<b>V</b>	24	24	24
<b>Machine size</b>	<b>cm X/Y/Z</b>	167x86x115,5	163x76x115,5	167x86x115,5
<b>Total oscillation value</b>	<b>m/s<sup>2</sup></b>	<2,5	<2,5	<2,5

**TECHNICAL SPECIFICATION:**

		<b>101 BF 70/72 S</b>	<b>101 BF 85 S</b>	<b>131 BF 100 S</b>
<b>Cleaning width</b>	<b>mm</b>	700/720	850	1000
<b>Squeegee width</b>	<b>mm</b>	1000	1150	1150
<b>Capacity per hour theor.</b>	<b>m<sup>2</sup>/h</b>	3850	4675	5500
<b>Maximum speed</b>	<b>km/h</b>	5,5	5,5	5,5
<b>Number of brushes</b>	<b>no.</b>	2	2	2
<b>Brush diameter</b>	<b>mm</b>	370	430	370
<b>Max. brush pressure</b>	<b>kg</b>	40	45	54
<b>Pressure of brush head on the ground</b>	<b>g/cm<sup>2</sup></b>	270	225	240
<b>Brush rotation speed</b>	<b>rpm</b>	180	180	180
<b>Brush motor power</b>	<b>W</b>	600	600	600
<b>Drive</b>	<b>-</b>	ELECTRONIC	ELECTRONIC	ELECTRONIC
<b>Nominal drive motor power</b>	<b>W</b>	850	850	1100
<b>Suction motor power</b>	<b>W</b>	550	550	660
<b>Sound pressure</b>	<b>dB(A)</b>	83	83	85
<b>Solution tank</b>	<b>l</b>	100	100	130
<b>Collection tank</b>	<b>l</b>	100	100	130
<b>Diaphragm</b>	<b>/</b>	Yes	Yes	Yes
<b>Drive wheel diameter</b>	<b>mm</b>	250	250	250
<b>Pivoting wheel diameter</b>	<b>mm</b>	160	160	160
<b>Net weight without batteries</b>	<b>kg</b>	212	221	268
<b>Number of batteries</b>	<b>no.</b>	4	4	6
<b>Voltage of batteries in series</b>	<b>V</b>	24	24	36
<b>Machine size</b>	<b>cm X/Y/Z</b>	163x76x115,5	167x86x115,5	168x102x115,5
<b>Total oscillation value</b>	<b>m/s<sup>2</sup></b>	<2,5	<2,5	<2,5

## 9. CE CONFORMITY DECLARATION

We hereby declare that the machine described below complies with the relevant basic safety and health requirements of the EU Directives, both in its basic design and construction as well as in the version put into circulation by us. This declaration shall cease to be valid if the machine is modified without our prior approval.

**Product:** Floor cleaner  
**Type:** Premium Green Line

**Relevant EU Directives**

2006/42/CE  
2004/108/CE  
2000/14/CE

**Applied harmonized standards**

EN 50106:2009-07-01  
EN 55014-1: 2007-06

**Applied national standards**

DIN EN 60335-1: 2007-02  
DIN EN 60335-2-72  
DIN EN 60529: 1991 + A1: 2000

The undersigned act on behalf and under the power of attorney of the company management.



R. Mimmler  
Technical Director



H. Waschke  
Product Standard Compliance

IP Gansow GmbH  
Dreherstraße 9  
59425 Unna  
Tel.: +49 (0)2303 2580 0  
Fax: +49 (0)2303 2580 199



## 10. SPECIAL INFORMATION FOR USING THE BATTERIES AND CHARGER

Do you know how much a set of batteries costs?

Between about 650 and 2000 € according to the size of your machine. Should you have armoured tube batteries, the cost of a set is between 2500 and 2100 €.

Reason enough, we think, to give these expensive energy units the necessary daily attention required, in order to achieve the greatest possible working life from them.

To ensure even greater protection for your batteries, we stock a battery condition indicator which shows the state of the battery at any given time. This instrument (type: BEM) is a panel type and can be fitted in the panel on any of our battery-powered machines.

Luminous diodes of various colours are used to indicate the different levels of voltage. The device can also be used to switch the brush motor(s) off automatically as soon as the battery reaches a fix state of discharge. Please feel free to consult the staff at our local sales depots or dealers for information on using and fitting these instruments as well as on the way they work.

**Points you really must take notice of:**

***- Never discharge the batteries too low.***

Every battery should only be discharged to 70 or 80% of its rated capacity. You will overburden the batteries,

- a) if you use your machine too long, too often. How long you can safely work your machine, will be explained to you, when our service personnel installs your equipment. You can ask our service personnel at any time, or call our nearest service depot. For machines fitted with a BEM the brushes will automatically be switched off when the battery voltages becomes too low.

- b) if you use your machine regularly more than once within 24 hours to a certain extend. A good battery charger requires continuously approx. 10 - 12 hours (according to type) to recharge empty batteries. If you interrupt the charging process, the batteries will never become fully charged, and will be quickly ruined.
- c) if you do not recharge the batteries immediately after having used them to about 70 or 80% of their rated capacity. Empty batteries do not have the power for a further operation, and will be quickly ruined. For machines fitted with a BEM the brushes will automatically be switched off when the battery voltages becomes too low.  
If you use your machine daily for (a) short period(s) only, ask at your nearest agency, or our service personnel. We will inform you as to the most practical way to use your charger to avoid premature corrosion of the battery.

#### **- Storage of batteries**

If batteries are taken out of service for a lengthy period they should be stored fully charged in a dry, frost-free room. To ensure the battery is always ready for use a choice of charging methods can be made:

- a) **A quarterly full charge.**  
If loads are connected, e.g. BEM, a full charge could be needed after 3 weeks.
- b) Float charging at the instructed charging voltage.

#### **- Correct connection of the battery charger.**

Please take careful note that:

- d) the plug of the charger cable is firmly plugged into the machine;
- e) the mains plug is firmly fitted into the wall socket. Confirm that the wall socket has electrical feed overnight and hang a notice on the plug, saying, that during the charging period the plug, must not be removed;
- f) the battery charger will switch itself on automatically after 15 seconds.

Before leaving the machine, please check carefully, that all connections are properly made and that the charger is switched on. Many batteries have been damaged prematurely because something has been overlooked. Please read the operating instructions of the type of charger in use with you.

**- *Secure seating of the post terminals on the cables, that join the batteries together.***

Loose battery post terminals are dangerous because a layer builds up that hinders the flow of electricity. When recharging the batteries, full electrical charge cannot flow, the batteries will not become fully charged and are therefore damaged prematurely. Should you find loose post terminals, please do not simply tighten them, but remove them, clean the post and the terminal inside and out, smear with battery grease and refit tightly.

**- *Run-in instruction***

Note that brand-new batteries need a running-in period and thus can not yet supply full power during the first 8 - 10 discharges. Therefore, the machine should be kept off heavy duty jobs during that time.

Should you have any further questions about the handling of your battery machine, please call our nearest office or agency.

**- *\*Never let the batteries get dry.***

The electrolyte must cover the cell plates at all times, it should be at least 5/8 ths of an inch over the plates. Cell plates that are continuously dry or part dry, build up a layer that prevents the cells from charging, rendering the battery useless within a short time.

**- *\*Never overfill the batteries.***

Too much electrolyte is as bad as too less. Only top up to approx. 5/8 ths of an inch above the cell plates.

**Important in breaching with battery acid - corrosive!**

**- *\*Always top up the batteries with distilled water, never acid.***

The only thing that vaporises when the batteries are warm, is the distilled water, therefore it is only necessary to top up with distilled water. Topping up with acid, makes the electrolyte too strong, and causes corrosion on the cell plates.

**Important in breaching with battery acid - corrosive!**

\*this does not apply to maintenance-free batteries

- ***\*Never top up with tap water.***

Tap water has an electrical conductivity and will destroy the batteries. You can purchase distilled water at Electrical Wholesalers, from us, or from Petrol Stations.

If you have any further questions about the handling of our battery machines then please contact your nearest **Gansow** representative or our head quarter in Unna / Germany.

\*this does not apply to maintenance-free batteries

## 11. CONTROL AND MAINTENANCE OPERATIONS:

### IMPORTANT !

***Repairs should preferably be performed by qualified personnel.***

Only original spare-parts may be used. Modification of the machine without the approval of the manufacturer or the use of unauthorised materials invalidates the warranty as the structural condition of the machine may differ from that described in the certificate

After any repair work by unauthorised personnel the machine must be officially approved by Gansow or a technician authorised by the company to confirm conformity with the original conditions and therefore the validity of the general terms of the warranty.

Before any cleaning or servicing work is carried out on the machine, disconnect the charger cable and remove the key from the key switch to guarantee operator safety.

### IMPORTANT SAFEGUARDS

***The following tasks should be carried out daily before or after each work session:***

- remove dirty water and rinse out the tank,
- clean the machine (do not use water jets or water cleaners)
- rinse the suction hose by running water from inside the tank,
- charge battery and check that the battery terminals and power plug are securely in position
- clean the electrodes and check the level of the dirty water and foam,
- make sure the tank lid fits correctly to the tank.

**Table of recommended checks, inspections and maintenance and schedule, based on daily use of about four hours;**

Description of control	interval	interval	interval	interval	interval
	WK.LY	MTH.LY	4/MTH	6/MTH	YR.LY
<b>1. General controls</b>					
Check the fixing and condition of the brush	X				
Check for water leaks from the tanks			X		
Clean the solution tank filters	X				
Make sure the switches and indicator lights on the panel are working correctly	X				
Check that the squeegee blades are not worn or damaged	X				
Check that the squeegee is correctly adjusted and adheres to the ground when suction is activated	X				
Grease the head raising and squeegee lever rotation pins		X			
Make sure there are no foreign bodies in the drive wheels and check the tyres are not worn		X			
<b>2. Motors</b>					
Check, if possible, wear of the drive motor carbon brushes and replace if necessary			X		
Check wear of the brush motor carbon brushes and replace if necessary (battery powered models only)			X		
Check wear of the suction motor carbon brushes and replace if necessary			X		
<b>3. Drive</b>					
Ensure cables are not damaged or loose			X		

Description of controls	interval	interval	interval	interval	interval
	WK.LY	MTH.LY	4/MTH	6/MTH	YR.LY
<b>4. Collection tank</b>					
Make sure the drain hoses are not blocked	X				
Make sure the suction hose is not blocked		X			
<b>5. Batteries</b>					
Check the condition of the cables and the seal of the cell caps.		X			
If the machine is not used and the batteries are active, recharge every three months			X		
Top up the level of battery fluid in all cells. (not necessary with gel batteries)	X				
Grease the battery terminals (not necessary with gel batteries).			X		
<b>Call the authorised Gansow technical assistance service for a full control</b>					
				X	

IP Gansow GmbH  
 Dreherstraße 9  
 59425 Unna  
[www.gansow.de](http://www.gansow.de)  
[kundendienst@gansow.de](mailto:kundendienst@gansow.de)  
 Tel.: 0049 (0)2303 2580-0

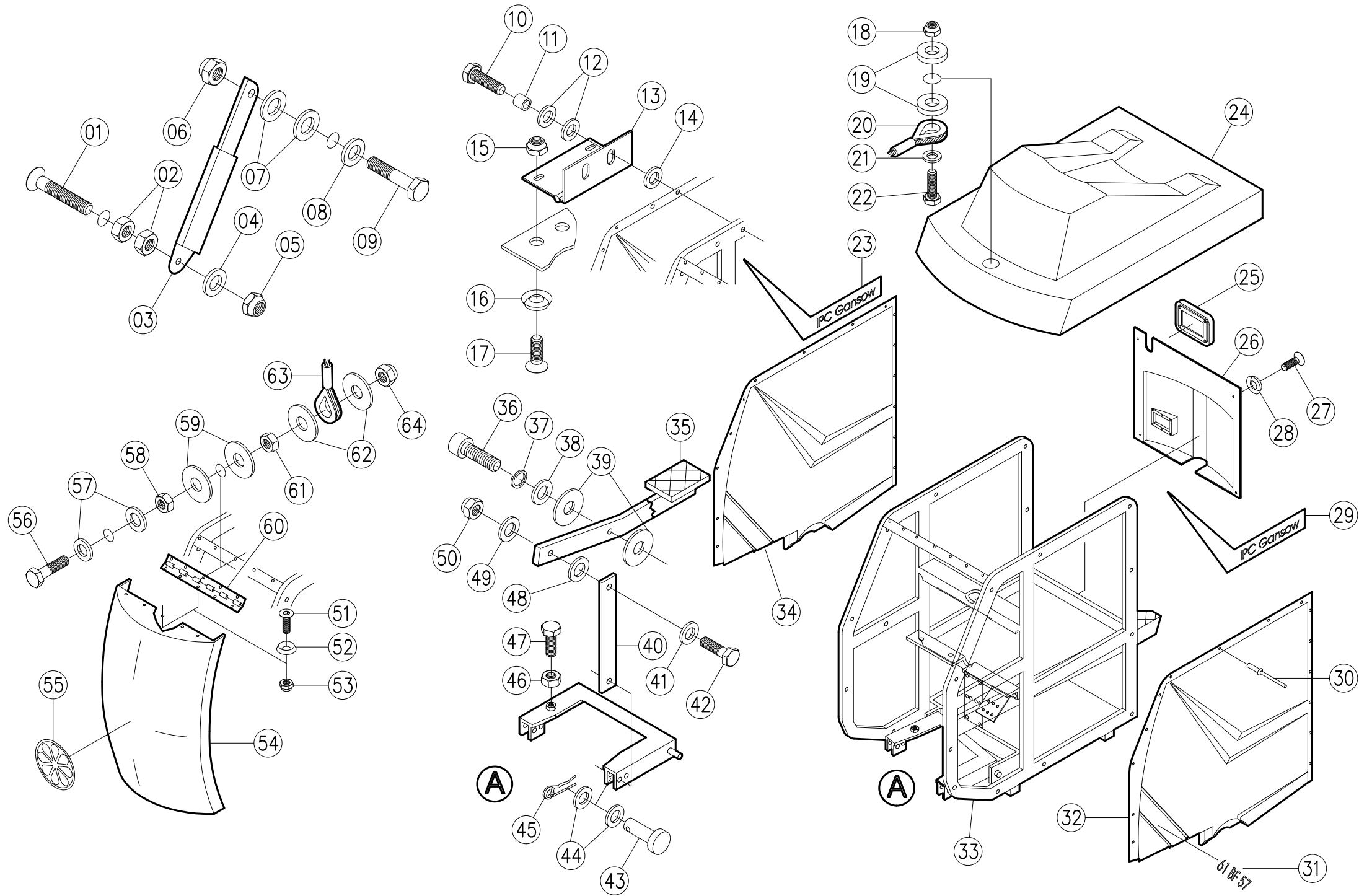



Position	Menge	Artikel-Nr.	IPC	Bezeichnung	Description	bis / up to	ab / from
0001	1	05328	VTVT00173	Schraube, Senkkopf-, M 6 x 25	countersunk head screw, M 6 x 25		
0002	2	05096	VTDD00482	Mutter, Sechskant, M 6	hexagonal screw, M 6		
0003	1	01728	LAFN01252	Stütze, Aufstell-, für vorderen Deckel	support for front lid		
0004	1	05119	VTRS00041	Scheibe, Unterleg-, M 6	washer, M 6		
0005	1	05218	VTDD86633	Mutter, Sechskant-, selbstsichernd, M 6	hexagonal nut, selfsealing, M 6		
0006	1	05218	VTDD86633	Mutter, Sechskant-, selbstsichernd, M 6	hexagonal nut, selfsealing, M 6		
0007	2	05119	VTRS00041	Scheibe, Unterleg-, M 6	washer, M 6		
0008	1	05119	VTRS00041	Scheibe, Unterleg-, M 6	washer, M 6		
0009	1	05012	VTVT00444	Schraube, Sechskant, M 6 x 20	hexagonal screw, M 6 x 20		
0010	4	05503	VTVT14095	Schraube, Zylinderkopf-, M 6 x 16	allen cap screw, M 6 x 16		
0011	4	01693	LAFN01250	Hülse, Distanz-, 8 x 3 mm	spacer sleeve, 8 x 3 mm		
0012	8	05119	VTRS00041	Scheibe, Unterleg-, M 6	washer, M 6		
0013	2	14278	CEVR00018	Deckelscharnier, 80 x 80 x 1,5 mm	hinge for top lid, 80 x 80 x 1,5 mm		
0014	4	05119	VTRS00041	Scheibe, Unterleg-, M 6	washer, M 6		
0015	4	05217	VTDD00026	Mutter, Sechskant-, selbstsichernd, M 5	hexagonal nut, selfsealing, M 5		
0016	4	05557	VTRS00067	Rosette, M 5, schwarz	collar, M 5, black		
0017	4	05065		Schraube, Linsensenkkopf-, M 5 x 18	raised countersunk head screw, M 5 x 18		
0018	1	05218	VTDD86633	Mutter, Sechskant-, selbstsichernd, M 6	hexagonal nut, selfsealing, M 6		
0019	2	05119	VTRS00041	Scheibe, Unterleg-, M 6	washer, M 6		
0020	1	13449	CMCV00071	Seil, Edelstahl-, für oberen Deckel	cable rope for top lid		
0021	1	05119	VTRS00041	Scheibe, Unterleg-, M 6	washer, M 6		
0022	1	05259	VTVT01531	Schraube, Sechskant, M 6 x 16	hexagonal screw, M 6 x 16		
0023	1	31215		Aufkleber, Keil, grün, rechts, 41/61/91 B/BF	sticker,wedge form,gr.,right,41/61/91B/BF		
0024	1	31228		Deckel, oberer-, grün, 61 B/BF	top lid, green, 61 B/BF		
0025	1	06925	MEVR00331	Deckel für Sicherungsautomaten	lid for automatic cut-out		
0026	1	31217		Platte, Abdeck-, am Gestell, 41/61 B/BF	cover at the frame, 41/61 B/BF		
0027	1	05461	VTVT00184	Schraube, Selbstschneidend, M 5 x 16	self tapping screw, M 5 x 16		
0028	1	05557	VTRS00067	Rosette, M 5, schwarz	collar, M 5, black		
0029	1	31214		Aufkleber, Keil, grün, links, 41/61/91 B/BF	sticker,wedge form,gr.,left,41/61/91B/BF		
0030	30	05157	VTVR00073	Niete, Blind-, 4 x 12	rivet, 4 x 12 mm		
0031	2	31244		Aufkleber, grün, 61 BF 57	sticker, green, 61 BF 57		
0032	1	31219		Seitenverkleidung, links, 41/61/91 B/BF	side cover, left, 41/61/91 B/BF		
0033	1	24002		Gestell, 41/61 B/BF	frame, 41/61 B/BF		
0034	1	31220		Seitenverkleidung, rechts, 41/61/91 B/BF	side cover, right, 41/61/91 B/BF		
0035	1	02451	LAFN01276	Hebel für Bürstenkopf, 41/61 B/BF	brush head lever, 41/61 B/BF		
0036	1	05209	VTVT00158	Schraube, Zylinderkopf-, M 10 x 25	allen cap screw, M 10 x 25		
0037	1	05133	VTRS01081	Federring, M 10	spring washer, M 10		

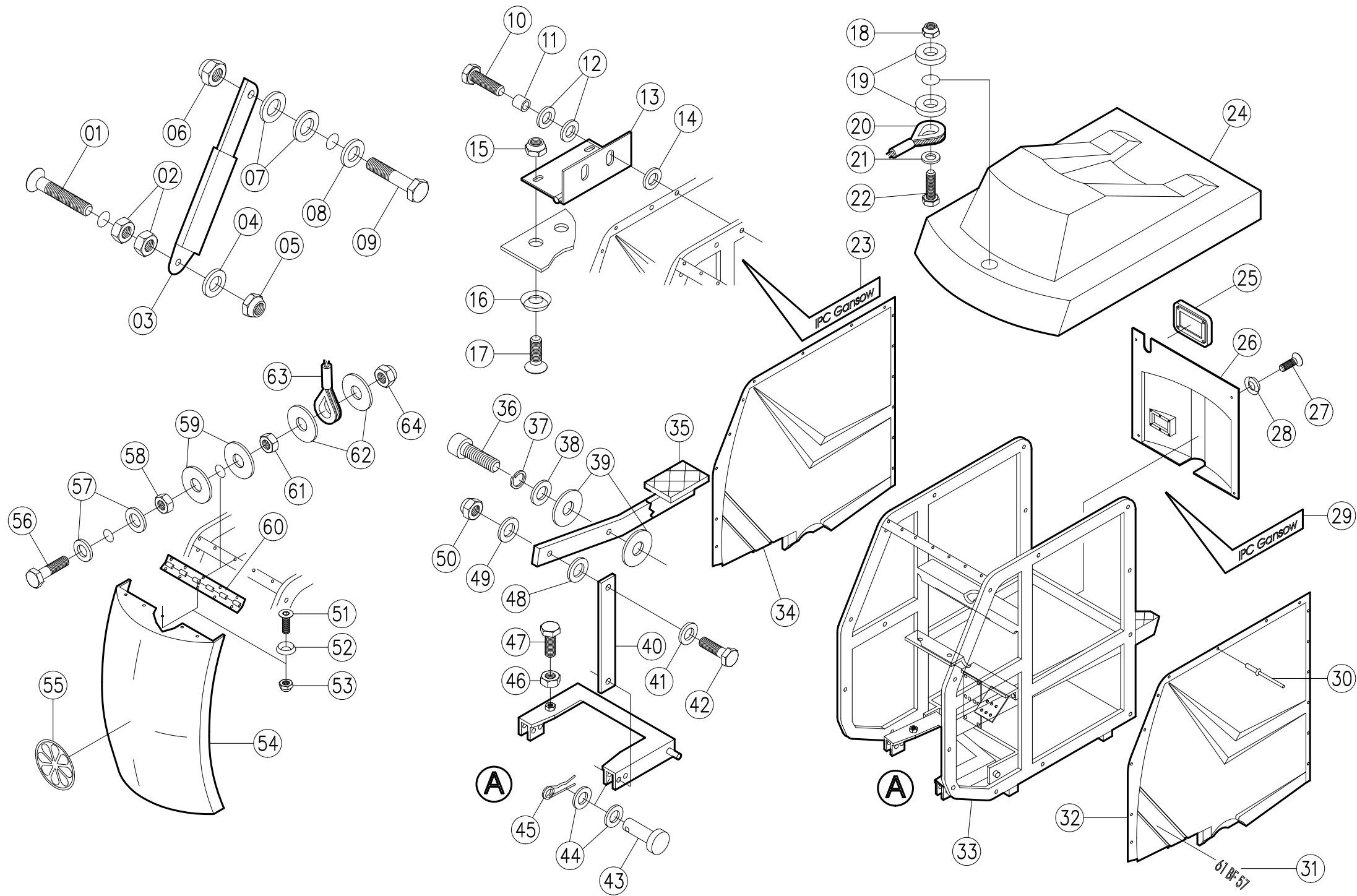

0038	1	05116	VTRS00505	Scheibe, Unterleg-, M 10	washer, M 10		
0039	2	05114	VTRS00040	Scheibe, Unterleg-, 12 x 18 x 1 mm	washer, 12 x 18 x 1 mm		
0040	1	24003	LAFN01392	Verbindungsflasche,Bürstenkopf,41/61B/BF	connection link, 41/61 B/BF		
0041	1	05116	VTRS00505	Scheibe, Unterleg-, M 10	washer, M 10		
0042	1	05016	VTVT00141	Schraube, Sechskant, M 10 x 30	hexagonal screw, M 10 x 30		
0043	1	01786	VTVR00062	Bolzen mit Kopf, 12 x 55 mm	bolt with head, 12 x 55 mm		
0044	2	05126	VTRS00506	Scheibe, Unterleg-, M 12	washer, M 12		
0045	1	01677	VTVR00061	Federstecker, 3,2 mm	spring clip, 3,2 mm		
0046	1	05103	VTDD01682	Mutter, Sechskant, M 12	hexagonal screw, M 12		
0047	1	05303	VTVT00167	Schraube, Zylinderkopf-, M 12 x 40	allen cap screw, M 12 x 40		
0048	1	05116	VTRS00505	Scheibe, Unterleg-, M 10	washer, M 10		
0049	1	05116	VTRS00505	Scheibe, Unterleg-, M 10	washer, M 10		
0050	1	05219	VTDD00027	Mutter, Sechskant-, selbstsichernd, M 10	hexagonal nut, selfsealing, M 10		
0051	5	05058	VTVT00146	Schraube, Linsensenkkopf-, M 5 x 14	raised countersunk head screw, M 5 x 14		
0052	5	05557	VTRS00067	Rosette, M 5, schwarz	collar, M 5, black		
0053	5	05217	VTDD00026	Mutter, Sechskant-, selbstsichernd, M 5	hexagonal nut, selfsealing, M 5		
0054	1	31221		Deckel, vorderer-, grün, 41/61 B/BF	front lid, green, 41/61 B/BF		
0055	1	16597		Aufkleber, Limette	sticker, lime		
0056	1	05038		Schraube, Zylinderkopf-, M 5 x 30	allen cap screw, M 5 x 30		
0057	2	05117	VTRS00502	Scheibe, Unterleg-, M 5	washer, M 5		
0058	1	05098	VTDD01678	Mutter, Sechskant, M 5	hexagonal screw, M 5		
0059	2	05446	VTRS00056	Scheibe, Unterleg-, 5 x 15 mm	washer, 5 x 15 mm		
0060	1	14841	CEVR00021	Scharnier für vorderen Deckel, 340 mm	hinge for front lid, 340 mm		
0061	1	05098	VTDD01678	Mutter, Sechskant, M 5	hexagonal screw, M 5		
0062	1	13449	CMCV00071	Seil, Edelstahl-, für oberen Deckel	cable rope for top lid		
0063	2	05446	VTRS00056	Scheibe, Unterleg-, 5 x 15 mm	washer, 5 x 15 mm		
0064	1	05217	VTDD00026	Mutter, Sechskant-, selbstsichernd, M 5	hexagonal nut, selfsealing, M 5		

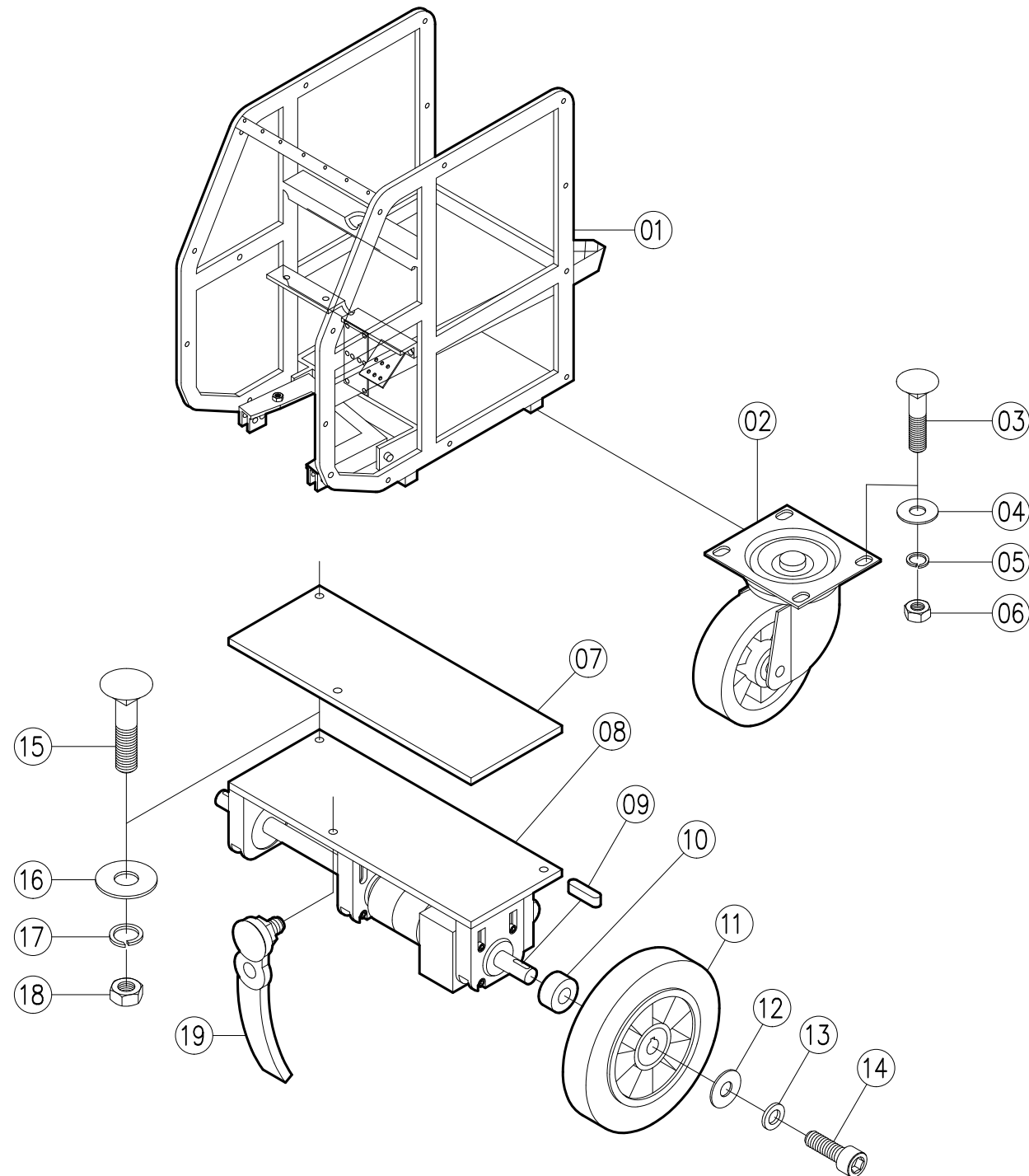

Position	Menge	Artikel-Nr.	IPC	Bezeichnung	Description	bis / up to	ab / from
0001	1	24002		Gestell, 41/61 B/BF	frame, 41/61 B/BF		
0002	1	14330	RTRT00063	Lenkrolle, 125 mm	caster wheel, 125 mm		
0003	4	75258	VTVT00326	Schraube, Schloss-, M 8 x 30	carriage bolt, M 8 x 30		
0004	4	75057	VTRS63243	Scheibe, Unterleg-, 8 x 24 mm	washer, 8 x 24 mm		
0005	4	05136	VTRS01080	Federring, M 8	spring washer, M 8		
0006	4	05094	VTDD10776	Mutter, Sechskant-, M 8	hexagonal nut, M 8		
0007	1	21513	LAFN01441	Getriebeunterbau, 41/61 BF	support for gear plate, 41/61 BF		
0008	1	13528	MOCC00043	Motor, Fahr-, 200 W, 41/61 BF	drive motor, 200 W, 41/61 BF		
0009	2	01676	VTVR21944	Passfeder, 6 x 6 x 30 mm	key, 6 x 6 x 30mm		
0010	2	13716	LAFN01343	Buchse-, Distanz-, 30 x 10 mm	bushing, 30 x 10 mm		
0011	2	16802		Rad, 230 mm	wheel, 230 mm		
0012	2	05127	VTRS00044	Scheibe, Unterleg-, 6 x 30 mm	washer, 6 x 30 mm		
0013	2	05296	VTRS00071	Federring, M 6	spring washer, M 6		
0014	2	75090	VTVT00262	Schraube, Zylinderkopf-, M 6 x 20	allen cap screw, M 6 x 20		
0015	3	05075	VTVT00155	Schraube, Schloss-, M 8 x 25	carriage bolt, M 8 x 25		
0016	3	75057	VTRS63243	Scheibe, Unterleg-, 8 x 24 mm	washer, 8 x 24 mm		
0017	3	05136	VTRS01080	Federring, M 8	spring washer, M 8		
0018	3	05094	VTDD10776	Mutter, Sechskant-, M 8	hexagonal nut, M 8		
0019	1	08430	MECI00069	Antistatikband	antistatic device		

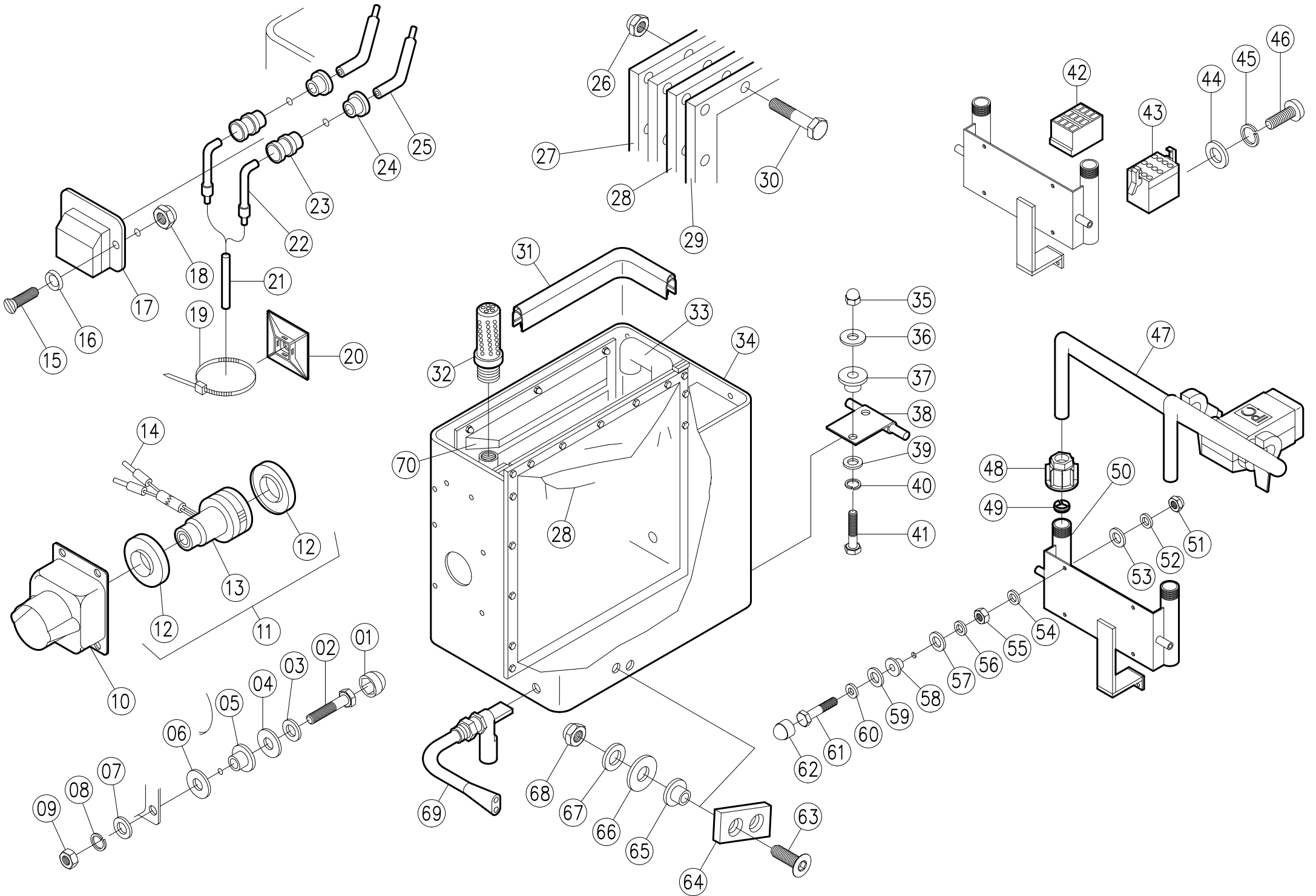

Position	Menge	Artikel-Nr.	IPC	Bezeichnung	Description	bis / up to	ab / from
0001	4	05359	MPVR60346	Abdeckkappe, Kunststoff-, M 6	cap for hexagonal nut, M 6		
0002	4	05241	VTVT06238	Schraube, Sechskant, M 6 x 35	hexagonal screw, M 6 x 35		
0003	4	05123	VTRS00043	Scheibe, Unterleg-, M 6	washer, M 6		
0004	4	05120	VTRS00042	Scheibe, Unterleg-, M 8	washer, M 8		
0005	4	05350	VTRS00052	Schraubensicherungsring, M 6	packing ring, plastic, M 6		
0006	4	05120	VTRS00042	Scheibe, Unterleg-, M 8	washer, M 8		
0007	4	05123	VTRS00043	Scheibe, Unterleg-, M 6	washer, M 6		
0008	4	05131	VTRS01079	Federring, M 6	spring washer, M 6		
0009	4	05096	VTDD00482	Mutter, Sechskant, M 6	hexagonal screw, M 6		
0010	1	30176	MPVR01136	Haube für Saugmotor, 61 B/BF	cover for suction motor, 61 B/BF		
0011	1	04976	PMVR00452	Motor, Saug-, 24 V, 3-stufig, komplett	suction motor, 24 V, 3-stages, complete		
0012	2	01448	GUVR00027	Dichtungsring für Turbine	sealing ring for suction motor		
0013	1	01293	MOMO00014	Motor, Saug-, 24 V, 3-stufig	suction motor, 24 V, 3-stages		
0014	2	06463	MEVR00199	Hülse, Aderend-, 2,5 mm <sup>2</sup>	cable end, 2,5 mm <sup>2</sup>		
0015	2	05321		Schraube, Senkkopf-, M 6 x 20	countersunk head screw, M 6 x 20		
0016	2	75168	VTRS00118	Rosette, M 6, schwarz	collar, M 6, black		
0017	1	30175	MPVR01135	Haube, Abdeck-, für Elektroden	probe cover		
0018	2	05218	VTDD86633	Mutter, Sechskant-, selbstsichernd, M 6	hexagonal nut, selfsealing, M 6		
0019	6	06365	FSVR00015	Abbinder	cable strap		
0020	6	14733		Abbinderhalter	holder for cable strap		
0021	1	06724	MEVR00239	Elektrodenkabel	probe cable		
0022	2	06784	MEVR00257	Rundsteckhülsen, PIDG-NYL	socket, PIDG-NYL		
0023	2	01733	MEVR00161	Verschraubung-, Kabel-, PG 7	probe holder, PG 7		
0024	2	13382	GUVR00034	Elektrodendichtung	probe sealing		
0025	1	40986	DBDB00919	Elektroden, Satz	probe, set		
0026	1	05240	VTDD05907	Mutter, Hut-, M 6, VA	cap screw, M 6, stainless steel		
0027	1	21437	LAFN01423	Rahmen für flexible Tankwand, 61/91 B/BF	frame for membrane, 61/91 B/BF		
0028	1	41136	DBDB00937	Tankwand, Flexible, 61/91 B/BF	membrane, 61/91 B/BF		
0029	1	21437	LAFN01423	Rahmen für flexible Tankwand, 61/91 B/BF	frame for membrane, 61/91 B/BF		
0030	1	05245	VTVT15141	Schraube, Sechskant, M 6 x 25, VA	hexagonal screw, M 6 x 25, stainless steel		
0031	1	31213		Tankdichtung, Green Line, Meterware	sealing for tank, Green Line, by the meter		
0032	1	04374	MPVR01049	Sieb, komplett, 130 mm	filter, complete, 130 mm		
0033	2	01620	RCVR00088	Rohrbogen, 90 Grad, 40 mm, PVC	elbow, 90 degree, 40 mm, PVC		
0034	1	31230		Tank, 61 B/BF	tank, 61 B/BF		
0035	4	05221	VTDD36474	Mutter, Hut-, M 8	cap nut, M 8		
0036	4	05121	VTRS17677	Scheibe, Unterleg-, M 10	washer, M 10		
0037	4	05351	VTRS00053	Schraubensicherungsring, M 8	packing ring, plastic, M 8		

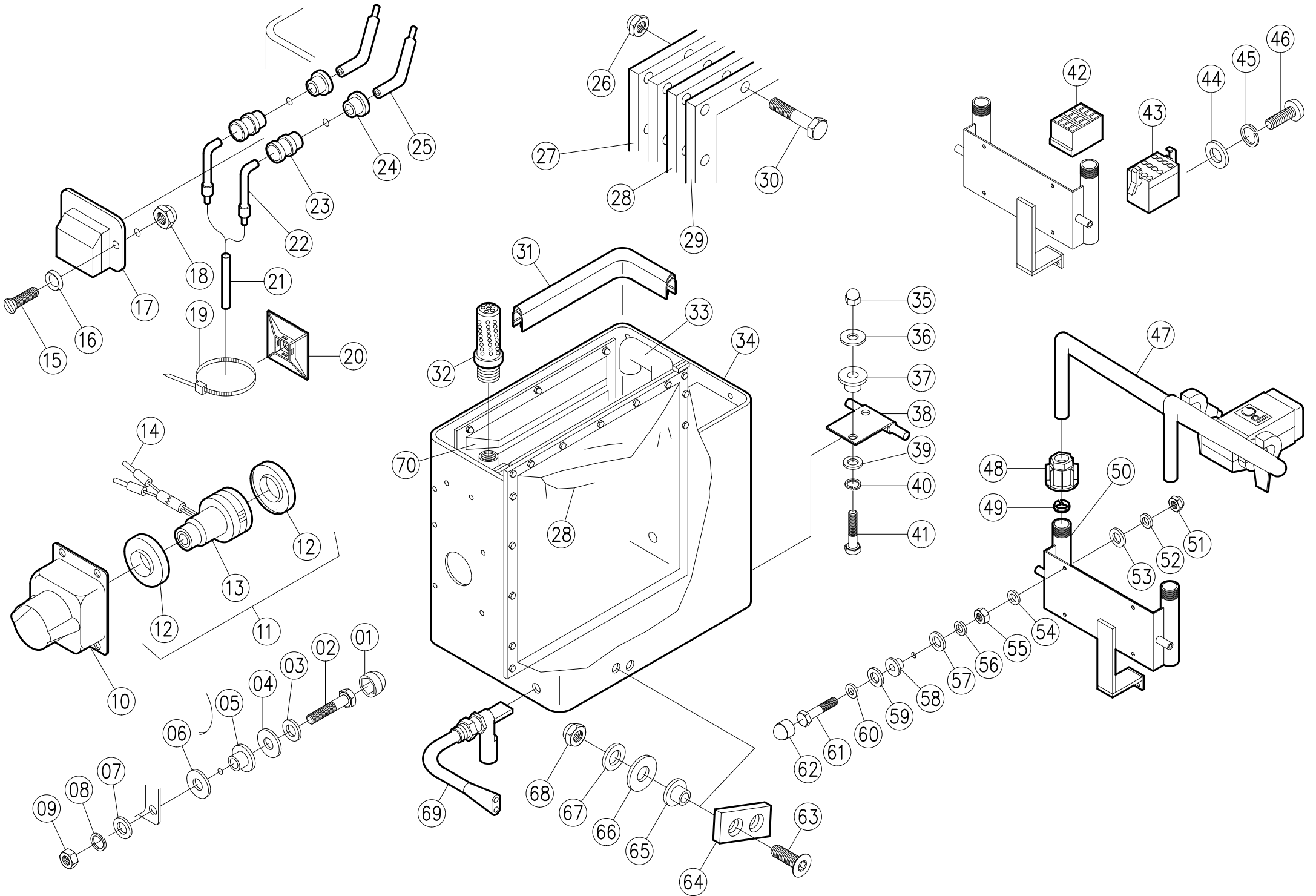



0038	2	02060	CEVR00016	Tankscharnier	tank hinge		
0039	4	05118	VTRS00503	Scheibe, Unterleg-, M 8	washer, M 8		
0040	4	05136	VTRS01080	Federring, M 8	spring washer, M 8		
0041	4	05250	VTVT00449	Schraube, Sechskant, M 8 x 35	hexagonal screw, M 8 x 35		
0042	1	31236		Buchse, 12-Polig	socket, 12-poles		
0043	1	31237		Stecker, 12-Polig	plug, 12-poles		
0044	4	05117	VTRS00502	Scheibe, Unterleg-, M 5	washer, M 5		
0045	4	05130	VTRS08013	Federring, M 5	spring washer, M 5		
0046	4	05319	VTVT00170	Schraube, Zylinderkopf-, M 5 x 8	allen cap screw, M 5 x 8		
0047	1	41168	DBDB00950	Lenkgriff, 41/61 BF	steering handle, 41/61 BF		
0048	2	13254	VTVR00086	Mutter, Überwurf-, für Lenkgriff	screw cap for steering handle		
0049	2	13261	PVVR00002	Klemmring, 25 mm	clamping ring, 25 mm		
0050	1	21345	LAFN01406	Lenkgriff Unterteil, 31/41/61 B/BF	steering handle, bottom part, 31/41/61 B/BF		
0051	4	05218	VTDD86633	Mutter, Sechskant-, selbstsichernd, M 6	hexagonal nut, selfsealing, M 6		
0052	4	05123	VTRS00043	Scheibe, Unterleg-, M 6	washer, M 6		
0053	4	05119	VTRS00041	Scheibe, Unterleg-, M 6	washer, M 6		
0054	4	05119	VTRS00041	Scheibe, Unterleg-, M 6	washer, M 6		
0055	4	05099		Mutter, Sechskant-, M 6	hexagonal nut, M 6		
0056	4	05123	VTRS00043	Scheibe, Unterleg-, M 6	washer, M 6		
0057	4	05120	VTRS00042	Scheibe, Unterleg-, M 8	washer, M 8		
0058	4	05350	VTRS00052	Schraubensicherungsring, M 6	packing ring, plastic, M 6		
0059	4	05120	VTRS00042	Scheibe, Unterleg-, M 8	washer, M 8		
0060	4	05123	VTRS00043	Scheibe, Unterleg-, M 6	washer, M 6		
0061	4	05017		Schraube, Sechskant, M 6 x 30	hexagonal screw, M 6 x 30		
0062	4	05359	MPVR60346	Abedckkappe, Kunststoff-, M 6	cap for hexagonal nut, M 6		
0063	2	05327	VTVT00179	Schraube, Senkkopf-, M 8 x 30	countersunk head screw, M 8 x 30		
0064	1	03515	LAFN01281	Tankhalter	buffer for tank		
0065	2	05351	VTRS00053	Schraubensicherungsring, M 8	packing ring, plastic, M 8		
0066	2	05121	VTRS17677	Scheibe, Unterleg-, M 10	washer, M 10		
0067	2	05242	VTRS00504	Scheibe, Unterleg-, M 8, VA	washer, M 8, stainless steel		
0068	2	05221	VTDD36474	Mutter, Hut-, M 8	cap nut, M 8		
0069	1		MECI00516	Schalter, Schwimmer-, SW-Tank,	float switch inside the clean water tank		
0070	2	HT1267	MPVR01578	Verstärkungswand, 61/91 B/BF	reinforcement plate, tank, 61/91 B/BF		

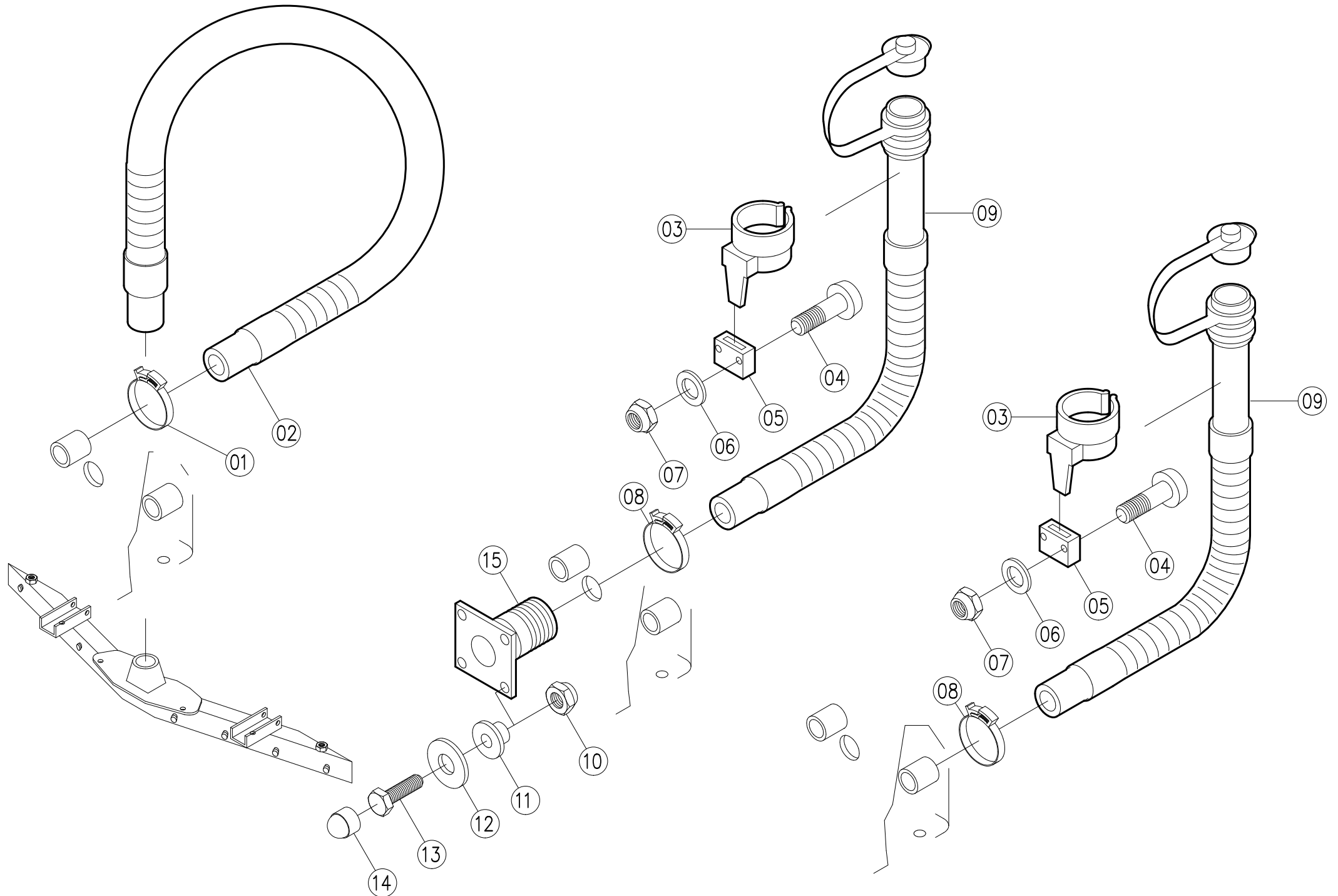

Position	Menge	Artikel-Nr.	IPC	Bezeichnung	Description	bis / up to	ab / from
0001	1	13933	MEVR00370	Schlauchklemme, 44 - 47,5 mm	hose clip, 44 - 47,5 mm		
0002	1	14716	TBFX00011	Schlauch, Saug-, 720 mm	suction hose, 720 mm		
0003	2	14672	MPVR01097	Clips, Schlauchhalterung-,	hose holding clip		
0004	4	05027	VTVT00877	Schraube, Zylinderkopf-, M 4 x 20	slotted head screw, M 4 X 20		
0005	2	14673	RCVR00125	Clips, Gegenstück,	clip counter part		
0006	4	75027	VTRS00515	Scheibe, Unterleg-, M 4	washer, M 4		
0007	4	05216	VTDD15925	Mutter, Sechskant-, M 4	hexagonal nut, M 4		
0008	2	13933	MEVR00370	Schlauchklemme, 44 - 47,5 mm	hose clip, 44 - 47,5 mm		
0009	2	16798		Schlauch, Ablass-, 800 mm	drain hose, 800 mm		
0010	4	05218	VTDD86633	Mutter, Sechskant-, selbstsichernd, M 6	hexagonal nut, selfsealing, M 6		
0011	4	05350	VTRS00052	Schraubensicherungsring, M 6	packing ring, plastic, M 6		
0012	4	05123	VTRS00043	Scheibe, Unterleg-, M 6	washer, M 6		
0013	4	05012	VTVT00444	Schraube, Sechskant, M 6 x 20	hexagonal screw, M 6 x 20		
0014	4	05359	MPVR60346	Abedckkappe, Kunststoff-, M 6	cap for hexagonal nut, M 6		
0015	1	21063	LAFN01402	Flansch, 1 1/4"	flange, 1 1/4"		

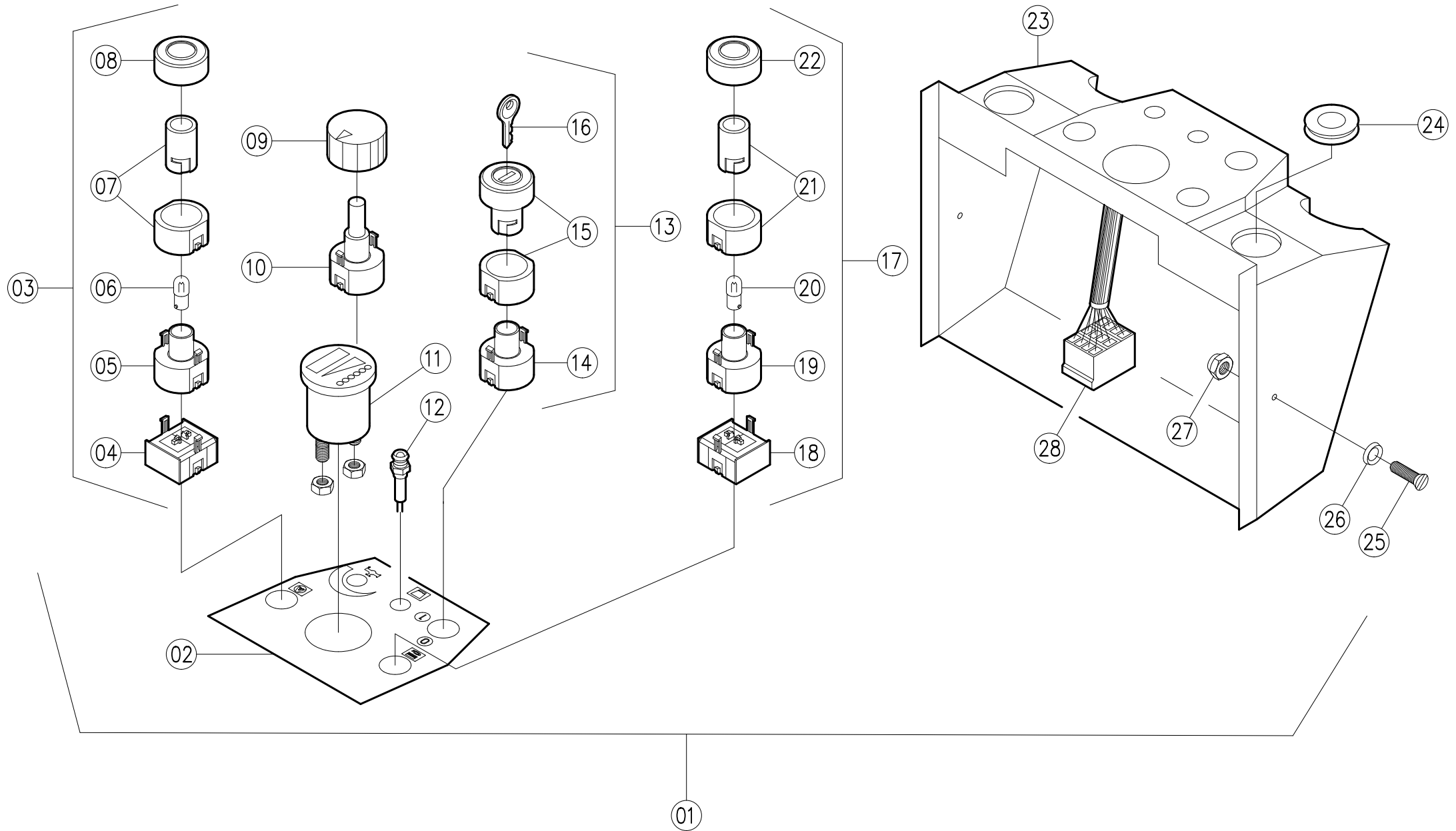

Position	Menge	Artikel-Nr.	IPC	Bezeichnung	Description	bis / up to	ab / from
0001	1	31238		Schaltkasten, komplett, 61 BF 57/68	switch box, complete, 61 BF 57/68		
0002	1	31232		Aufkleber, Schaltpult, 61B/41-131BF	sticker, switch board, 61B/41-131BF		
0003	1		KTRI15040	Schalter, Turbinen-, komplett	switch, turbine, complete		
0004	1		MECI00506	Schalter, Unterteil,	switch, bottom part		
0005	1		MECI00507	Lampenfassung	lamp socket		
0006	1	06345	MEVR00193	Lampenbirne, 2W, 30V	light bulb, 2W, 30V		
0007	1		MECI00501	Schalter, Oberteil,	switch, upper part		
0008	1		MECI00503	Schutzkappe, Schalter	protection cap		
0009	1	16154	MPVR01118	Knopf, Dreh-, mit Kappe schwarz	rotary knob with cap		
0010	1	06154	MECI00046	Poti für Wasserpumpensteuerung, 24 V	poti for water pump control, 24 V		
0011	1	16278	MESB00025	Batterieentladeanzeiger, 24 V	battery discharge indicator		
0012	1	11738		LED, rot	LED, red		
0013	1		KTRI15039	Schalter, Schlüssel-, komplett	key switch, complete		
0014	1		MECI00504	Schlüsselschalter, Unterteil,	key switch, bottom part		
0015	1		MECI00505	Schlüsselschalter, Oberteil,	key switch, upper part		
0016	1		AZMC00023	Schlüssel für Schlüsselschalter	key for key switch		
0017	1		KTRI15038	Schalter, Bürsten-, komplett	switch, brush, complete		
0018	1		MECI00502	Schalter, Unterteil,	switch, bottom part		
0019	1		MECI00507	Lampenfassung	lamp socket		
0020	1	06345	MEVR00193	Lampenbirne, 2W, 30V	light bulb, 2W, 30V		
0021	1		MECI00501	Schalter, Oberteil,	switch, upper part		
0022	1		MECI00503	Schutzkappe, Schalter	protection cap		
0023	1	31233		Schaltkasten, 61 B/BF 57/68	switch box, 61 B/BF 57/68		
0024	2	13486	GUVR00035	Dichtung für Lenkgriff	sealing for steering handle		
0025	2	75021	VTVT00234	Schraube, Senkkopf-, M 5 X 16	counter sunk screw, M 5 X 16		
0026	2	05557	VTRS00067	Rosette, M 5, schwarz	collar, M 5, black		
0027	2	05098	VTDD01678	Mutter, Sechskant-, M 5	hexagonal nut, M 5		
0028	1	31237		Stecker, 12-Polig	plug, 12-poles		

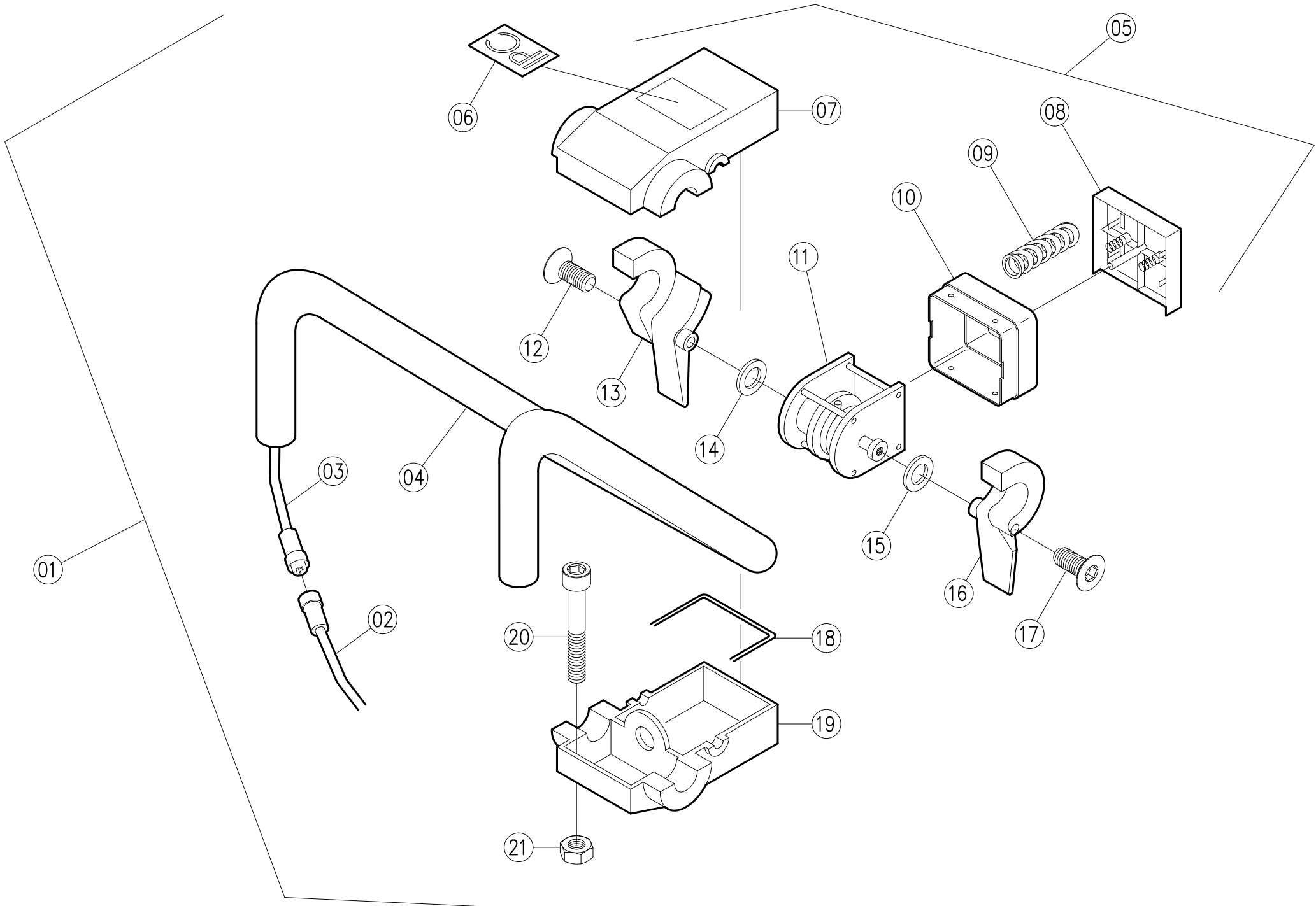

Position	Menge	Artikel-Nr.	IPC	Bezeichnung	Description	bis / up to	ab / from
0001	1	41168	DBDB00950	Lenkgriff, komplett, 41/61 BF	steering handle, complete, 41/61 BF		
0002	1	16395		Kabel, Buchsen-, 1550 mm	socket cable, 1550 mm		
0003	1	06785	CMCV00063	Kabel, Stecker für Lenkgriff	plug cable for steering handle		
0004	1	21960	LAFN01453	Lenkgriff, 41/61 BF	steering handle, 41/61 BF		
0005	1	41769	MECE00250	Schaltkasten, Deichsel-, komplett	switch box at steering handle, complete		
0006	1	31239		Aufkleber, IPC	sticker, IPC		
0007	1	13153	MPVR01079	Deichselsteuerkopf, Oberteil	switch box, upper part		
0008	1	13157	MPVR01080	Pralltaste für Deichselsteuerkopf	emergency switch for switch box		
0009	2	13209	MLML00289	Druckfeder für Aufpralltaste	pressure spring for emergency switch		
0010	1	13586	LAFN01338	Abdeckung für Pralltaste	cover for emergency switch		
0011	1	14255	MECI00084	Fahrschalter	drive switch		
0012	1	13205	VTVT00197	Schraube, Senkkopf-, M 4 x 20, VA	countersunk head screw, M 4 x 20		
0013	1	14675	MPVR04854	Flügelgriff, rechts	butterfly handle, right		
0014	1	13200	GUVR00030	Dichtung, Wellen-,	seal for shaft		
0015	1	13200	GUVR00030	Dichtung, Wellen-,	seal for shaft		
0016	1	14676	MPVR04855	Flügelgriff, links	butterfly handle, left		
0017	1	13205	VTVT00197	Schraube, Senkkopf-, M 4 x 20, VA	countersunk head screw, M 4 x 20		
0018	1	13577	GUVR01000	Dichtung für Deichselkasten	sealing for handle switch box		
0019	1	13168	MPVR01081	Deichselsteuerkopf, Unterteil	switch box, bottom part		
0020	2	75186	VTVT33568	Schraube, Zylinderkopf-, M 6 x 45	allen cap screw, M 6 x 45		
0021	2	05096	VTDD00482	Mutter, Sechskant-, M 6	hexagonal nut, M 6		

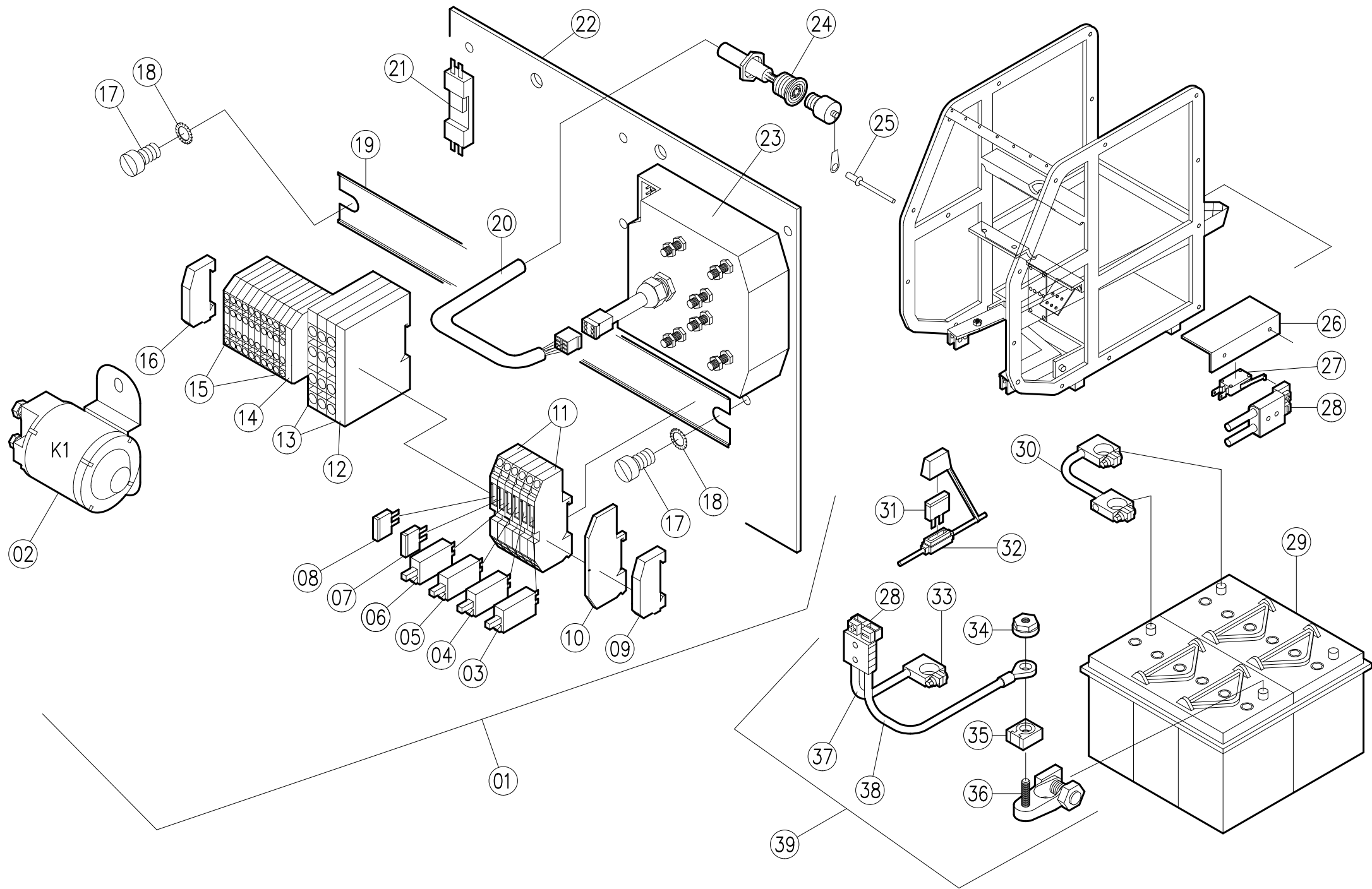



Position	Menge	Artikel-Nr.	IPC	Bezeichnung	Description	bis / up to	ab / from
0001	1	31240		Verdrahtungsplatte, komplett,41/61BF57/68	wiring plate, complete, 41/61 BF 57/68		
0002	1	06328	MECI00053	Schütz, 124 A	contactor, 124 A		
0003	1	14693		Sicherungsautomat, 15 A	automatic fuse, 15 A		
0004	1	14643	MEVR00379	Sicherungsautomat, 25 A	automatic fuse, 25 A		
0005	1	14643	MEVR00379	Sicherungsautomat, 25 A	automatic fuse, 25 A		
0006	1	14643	MEVR00379	Sicherungsautomat, 25 A	automatic fuse, 25 A		
0007	1	70165	MEVR00585	Sicherung, 5 A	fuse, 5 A		
0008	1	70241	MEVR00585	Sicherung, 7,5 A	fuse, 7,5 A		
0009	1	06619	LAFN01302	Endklammer für Tragschiene	limit angle for terminalline		
0010	4	13841	MEVR00369	Platte, Abschluss- u. Zwischen-, orange	end plate for terminalline		
0011	6	13840	MEVR00368	Sicherungsklemme, 2-Leiter	fuse clamp, 2 conductor		
0012	1	06617	MEVR00226	Platte, Abschluss- u. Zwischen-,	end plate for terminalline,		
0013	3	06616	MEVR00225	Klemme, Durchgangs-, 6 mm <sup>2</sup>	line-up terminal, 6 mm <sup>2</sup>		
0014	1	06618	MEVR00227	Platte, Abschluss- u. Zwischen-,	end plate for terminalline,		
0015	8	06615	MEVR00224	Klemme, Durchgangs-, 2,5 mm <sup>2</sup>	line-up terminal, 2,5 mm <sup>2</sup>		
0016	1	06619	LAFN01302	Endklammer für Tragschiene	limit angle for terminalline		
0017	2	05445	VTVT00182	Schraube, Linsenkopf-, M 5 x 6	raised countersunk screw, M 5 x 6		
0018	2	05140	VTRS00046	Fächerscheibe, M 5	serrated lock washer, M 5		
0019	1	06235	MEVR62076	Tragschiene	terminal line		
0020	1	16397		Kabel, Diagnose-,	cabel for diagnostic plug		
0021	1	14254	MECE00106	Schaumabschaltungsplatine	pcb for overfilling protection		
0022	1	24014		Grundplatte, Verdrahtungs-, 41/61BF57/68	wiring plate, drilled, 41/61 BF 57/68		
0023	1	16821		Steuerung, ACX-,	ACX control		
0024	1	13442	RCVR00119	Buchsenkappe	socket cap		
0025	1	05189	VTVR00067	Blindniete, 3 x 12 mm	rivet, 3 x 12 mm		
0026	1	24028		Platte-, Befestigungs-, Mikroschalter	fixing plate for microswitch		
0027	1	16433		Mikroschalter am Ladestecker	microswitch at charging plug		
0028	1	11333	MEVR00341	Stecker, Lade-, 50 A, rot	charging plug, 50 A, red		
0029	2	13287	BAAC00024	Batterie, 12V/105Ah	battery, 12V/105 Ah		
0030	1	14844	MEVR00385	Kabel, Verbindungs-, für 2 x 12 V Batterien	cable conection for 2 x 12 V batteries		
0031	1	70164	MEVR00564	Sicherung, 2 A	fuse, 2 A		
0032	1	14171	MEVR00377	Halter, Flachstecksicherungs-, mit Kabel	fuse holder with cable		
0033	1	01724	MEVR00160	Polklemme "Minus"	post terminal, minus		
0034	1	06920	VTDD00030	Isoliermutter für Sicherungseinsatz	insulating nut for fuse insert		
0035	1	06919	MEVR00330	Sicherungseinsatz, 100 A	fuse insert, 100 A		
0036	1	06957	MEVR00337	Batterieklemme, 1-fach, plus	post terminal, plus		
0037	1	06500	MEVR00209	Kabel, schwarz, 10 mm <sup>2</sup>	cable, blackred, 10 mm <sup>2</sup>		

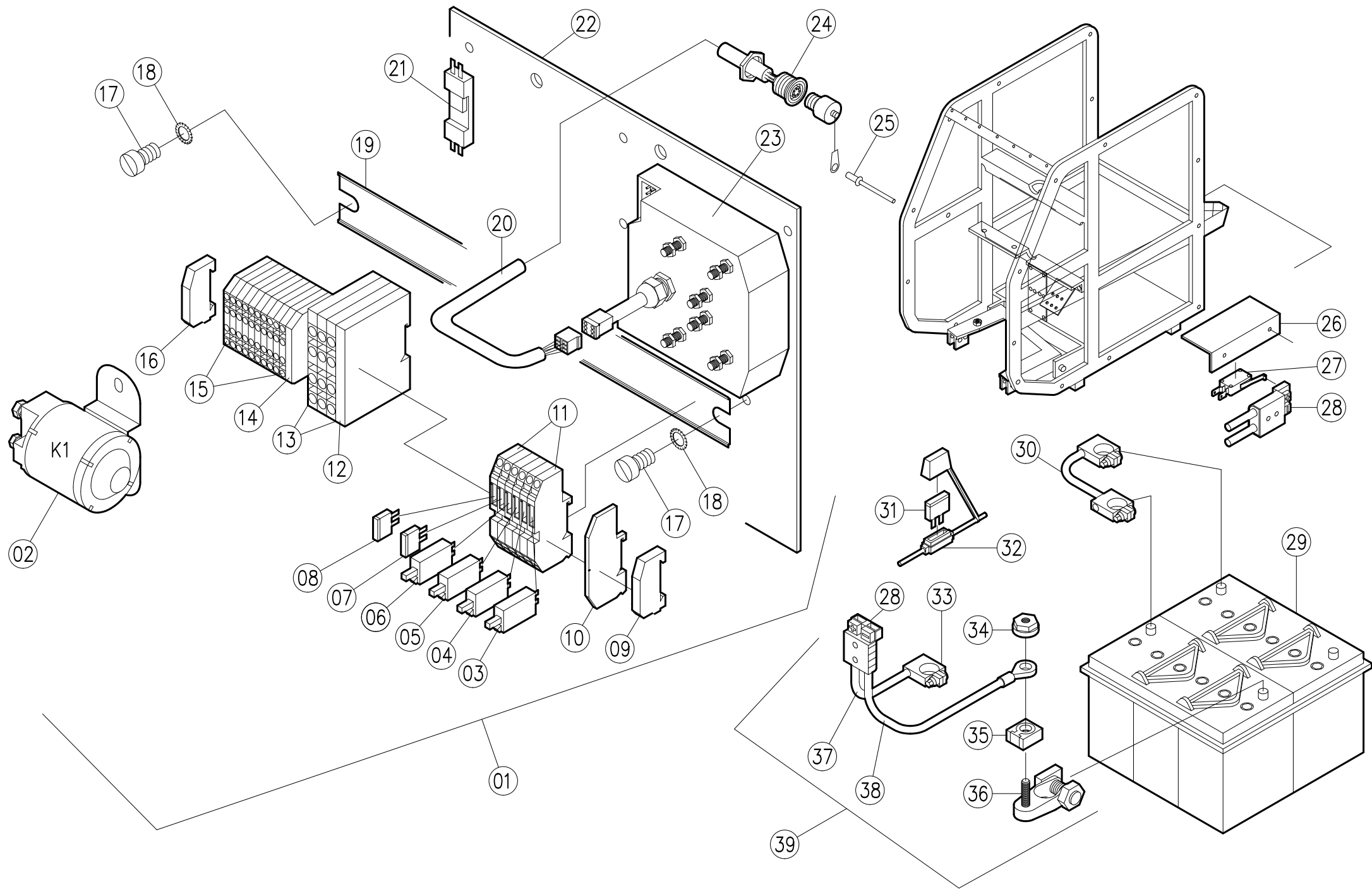

0038	1	06264	Kabel, rot, 10 mm <sup>2</sup>	06264	06264	cable, red, 10 mm <sup>2</sup>		
0039	1	31226	Batteriekabel, komplett, 41/61 B/BF 57/68	31226	31226	battery cable, complete, 41/61 BF 57/68		

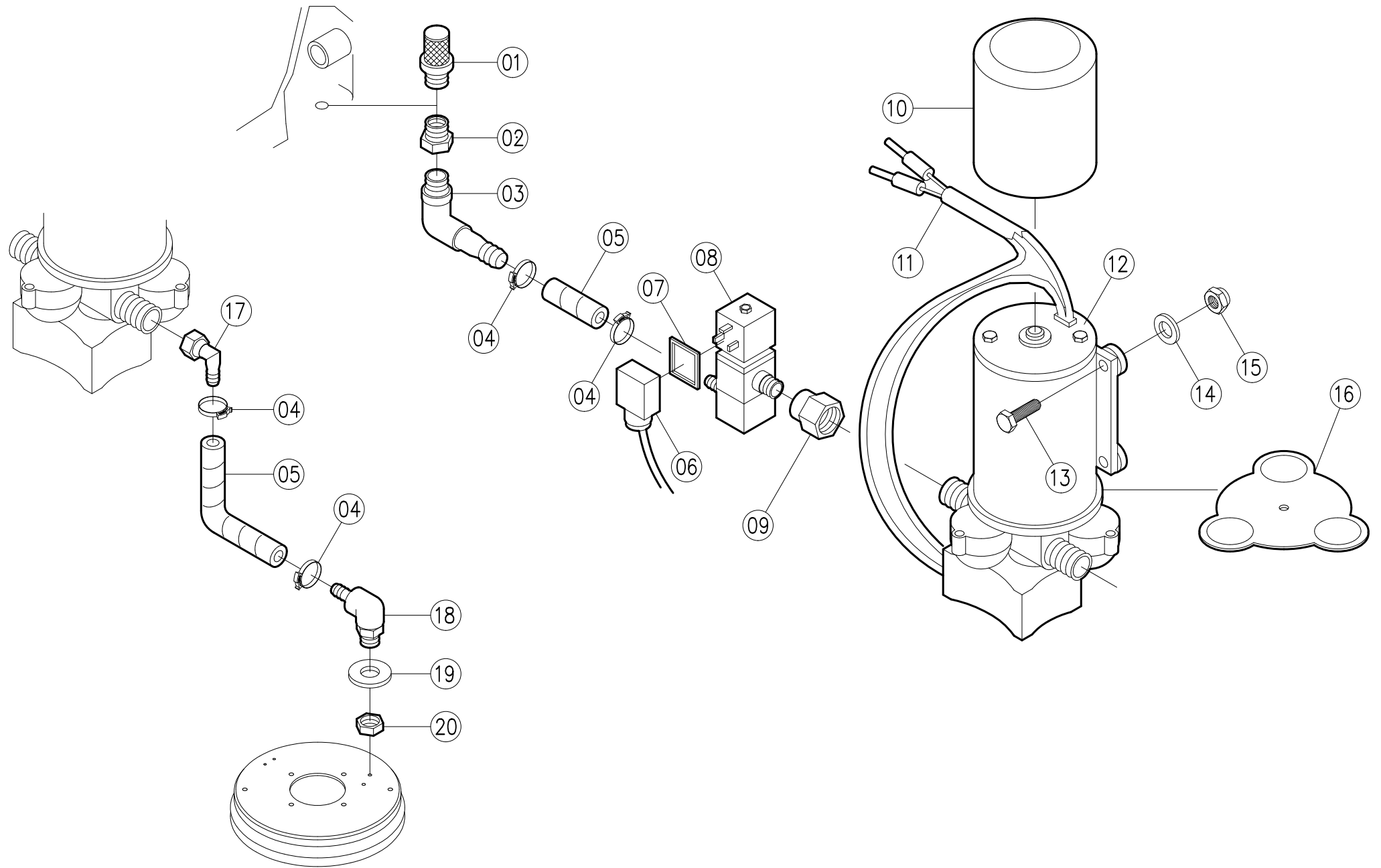

Position	Menge	Artikel-Nr.	IPC	Bezeichnung	Description	bis / up to	ab / from
0001	1	01399	FTAC00001	Stand-Sieb, 1/2"	strainer, 1/2", for clean water tank		
0002	1	01756	RCVR00091	Reduzierstück, 3/4" x 1/2"	reducer, 3/4 " x 1/2 "		
0003	1	12476	RCVR00109	Winkel-Einschraubstutzen, 12 mm	elbow, 90 degree, 12mm		
0004	4	13935	MEVR00372	Schlauchklemme, 18,2 - 20,5 mm	hose clip, 18,2 - 20,5 mm		
0005	2	01705	TBBP00045	Schlauch, PVC, 1/2"	hose, PVC, 1/2"		
0006	2	40912	DBDB00909	Magnetventilkabel	cabl for solenoide valve,		
0007	1	13923	GUVR00045	Dichtung für Magnetventilstecker	sealing for solenoide valve		
0008	1	13195	MECI00073	Magnetventil, 24V, 1/2"	solenoide valve, 24V, 1/2"		
0009	1	16089	RCVR00278	Reduzierstück, 1/2" auf 3/8", IG/IG	reduction, 1/2" to 3/8", f/f		
0010	1	14798	MPVR01098	Kappe, Abdeck-, für Wasserpumpe	cover for water pump		
0011	1	06859	MEVR00318	Kabel, Wasserpumpen-,	cabl for water pump		
0012	1	16807		Wasserpumpe, 24 V	water pump, 24 V		
0013	2	05013	VTVT06235	Schraube, Sechskant, M 6 x 30	hexagonal screw, M 6 x 30		
0014	2	05119	VTRS00041	Scheibe, Unterleg-, M 6	washer, M 6		
0015	2	05218	VTDD86633	Mutter, Sechskant-, selbstsichernd, M 6	hexagonal nut, selfsealing, M 6		
0016	1	16284		Ventilsatz, EPDM für Wasserpumpe	valve set, EPDM, for water pump		
0017	1	16385		Schlauchtülle, Winkel-, 1/2"	hose liner, 90°, 1/2"		
0018	1	12476	RCVR00109	Winkel-Einschraubstutzen, 12 mm	elbow, 90 degree, 12mm		
0019	1	11137	VTRS00068	Scheibe, Unterleg-, 21 x 38 x 3 mm, PVC	washer, 21 x 38 x 3 mm, PVC		
0020	1	01565	MEVR01906	Mutter, Gegen-, 1/2"	lock nut, 1/2"		

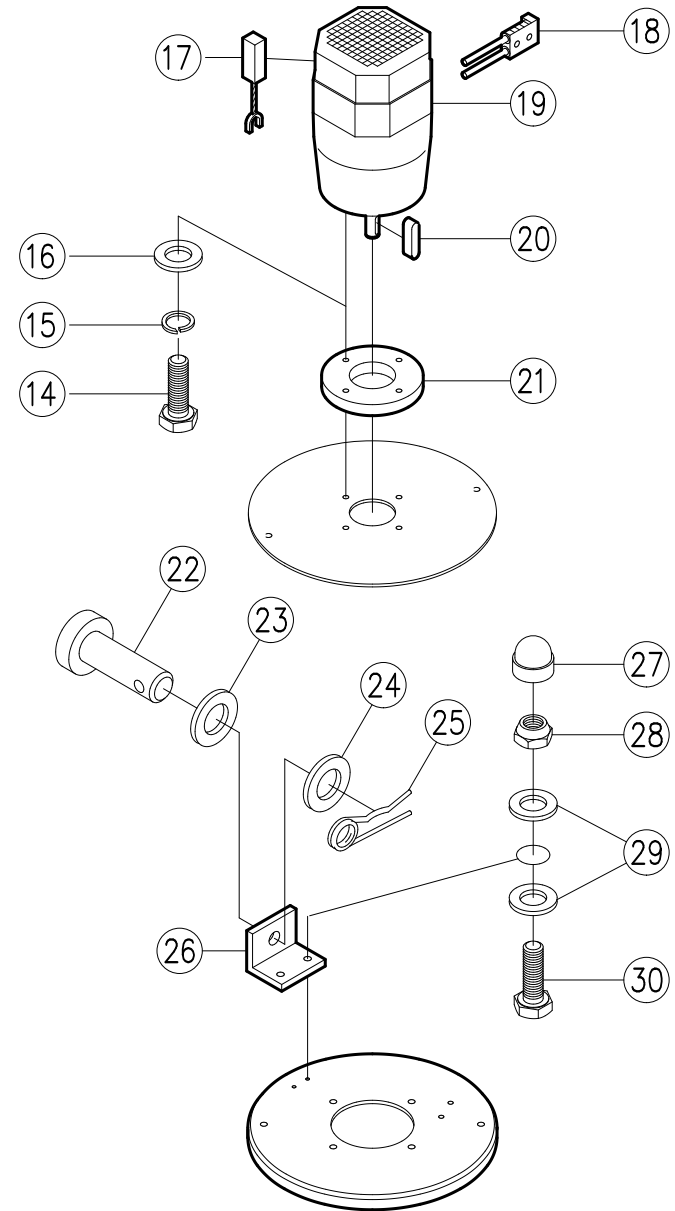
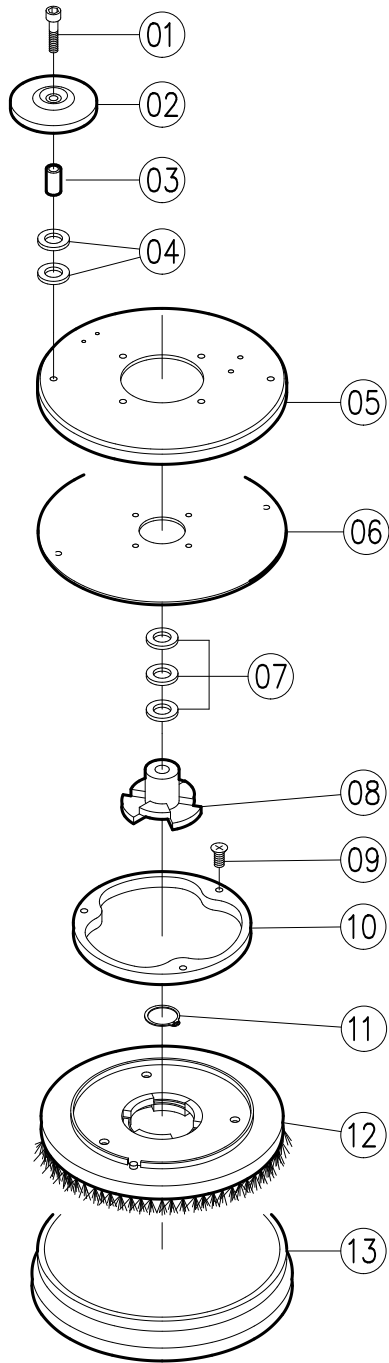

Position	Menge	Artikel-Nr.	IPC	Bezeichnung	Description	bis / up to	ab / from
0001	2	05138	VTVT01124	Schraube, Zylinderkopf-, M 10 x 35	slotted head screw, M 10 x 35		
0002	2	12370	RTRT00049	Ablenkrolle	guide roller		
0003	2	12469	LAFN01316	Buchse, 15/2 x 5 x 17,2mm, M 10	spacer sleeve, 15/2 x 5 x 17,2mm, M 10		
0004	4	05115	VTRS00509	Scheibe, Unterleg-, M 20	washer, M 20		
0005	1	03475	MPVR00982	Bürstenkopfronde, 41/61 B/BF 57	cover for brush head, 41/61 B/BF 53		
0006	1	22082	LAFN01458	Verstärkungspl. Bürstenkopf, 41/61B/BF57	reinforcing plate, brush head, 41/61B/BF57		
0007	3	05511	VTRS00061	Paßscheibe, 18 x 25 x 0,1 mm	coach body disc, 18 x 25 x 0,1 mm		
0008	1	13925	MFVR00030	Bajonettkupplung, 25 mm	bajonett coupling, 25 mm		
0009	1	05436	VTVT00180	Schraube, Selbstschneidend, M 3 x 25	self tapping screw, M 3 x 25		
0010	1	13256	GUVR00031	Wasserleitring, beidseitig	water guiding ring		
0011	1	05390	VTAE00018	Sprengring, 25 mm	circlip, 25mm		
0012	1	19259		Bürste, PPN 0,5, 530 mm	brush, ppn 0,5, 530 mm		
0013	1	41556	PMLA00139	Spritzgummi, Bürstenkopf 41/61 B/BF 57	splash skirt for brush head 41/61 B/BF 57		
0014	4	05271	VTVT00164	Schraube, Sechskant-, M 8 x 30	hexagonal screw, M 8 x 30		
0015	4	05136	VTRS01080	Federring, M 8	spring washer, M 8		
0016	4	05118	VTRS00503	Scheibe, Unterleg-, M 8	washer, M 8		
0017	1	14081	MEVR00374	Kohlebürsten für Bürstenmotor	carbon brush for brush motor		
0018	1	01081	MEVR00152	Stecker, Bürstenmotor, 50 A, schwarz	plug for brush motor, 50 A, black		
0019	1	13530	MOCC00045	Motor, Bürsten-, 24V/650W	brush motor, 24V/650W		
0020	1	12144	VTVR00080	Passfeder, 8 x 7 x 56 mm	key, 8 x 7 x 56 mm		
0021	1	14333	PVVR00005	Zwischenring, Bürstenmotor 41/61 B/BF 57	distance ring, brush motor 41/61 B/BF 57		
0022	2	01787	LAFN01253	Bolzen mit Kopf, 12 x 40 mm	bolt with head, 12 x 40 mm		
0023	2	05126	VTRS00506	Scheibe, Unterleg-, M 12	washer, M 12		
0024	2	05126	VTRS00506	Scheibe, Unterleg-, M 12	washer, M 12		
0025	2	01677	VTVR00061	Federstecker, 3,2 mm	spring clip, 3,2 mm		
0026	2	41123	LAFN01532	Winkel, Bürstenkopf, 41/61 B/BF 57	bracket for brush head, 41/61 B/BF 57		
0027	4	75135	MPVR01575	Abdeckkappe, M 8	cover for srew, M 8		
0028	4	05220	VTDD86484	Mutter, Sechskant-, selbstsichernd, M 8	hexagonal nut, self sealing, M 8		
0029	8	05118	VTRS00503	Scheibe, Unterleg-, M 8	washer, M 8		
0030	4	05250	VTVT00449	Schraube, Sechskant-, M 8 x 35	hexagonal screw, M 8 x 35		

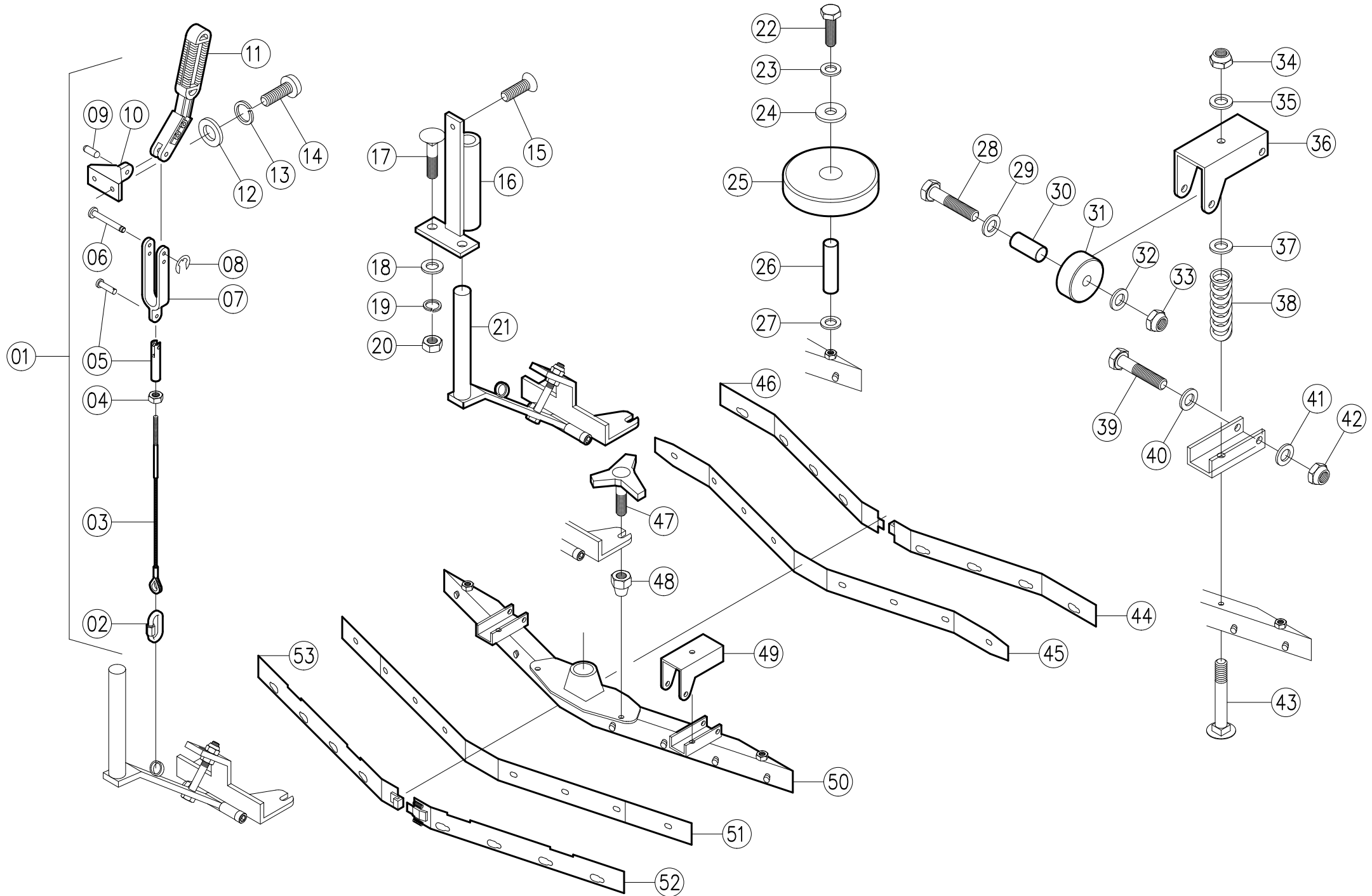



Position	Menge	Artikel-Nr.	IPC	Bezeichnung	Description	bis / up to	ab / from
0001	1	41159	PMVR00464	Saugfussheber, komplett	squeegee lift, complete		
0002	1	12226	VTVR00082	Schäkel, 5 mm	eye ring, open, 5 mm		
0003	1	13787	CMCV00076	Drahtseil, 350 mm	wire rope, 350 mm		
0004	1	75154	VTDD09556	Mutter, Sechskant, M 3	hexagonal screw, M 3		
0005	1	12839	CMCV00068	Gabelterminal, 3 mm	two-way beeches piece for wire rope, 3mm		
0006	1	13400	LAFN01335	Drehstift, 40 x 5 mm	rotary pin, 40 x 5 mm		
0007	1	13390	CMCV00070	Zugstange, schwarz	pull rod, black		
0008	1	05471	VTRS00057	Sicherungsscheibe, 5 mm	shaft protection, 5 mm		
0009	1	05472	MEVR00173	Stift, Zylinder-, 5 x 18 mm	cylindrical pin, 5 x 18 mm		
0010	1	13391	MPVR01089	Winkel für Saugfussheber	angle for squeegee lift		
0011	1	13389	MPVR01088	Saugfusshebergriff	handle for squeegee lift		
0012	2	05119	VTRS00041	Scheibe, Unterleg-, M 6	washer, M 6		
0013	2	05131	VTRS01079	Federring, M 6	spring washer, M 6		
0014	2	75090	VTVT00262	Schraube, Zylinderkopf-, M 6 x 20	allen cap screw, M 6 x 20		
0015	1	05051		Schraube, Senkkopf-, M 8 x 25	countersunk head screw, M 8 x 25		
0016	1	24007		Saugfußlager, 41/61B/BF	squeegee bearing, 41/61 B/BF		
0017	2	75258	VTVT00326	Schraube, Schloss-, M 8 x 30	carriage bolt, M 8 x 30		
0018	2	75057	VTRS63243	Scheibe, Unterleg-, 8 x 24 mm	washer, 8 x 24 mm		
0019	2	05136	VTRS01080	Federring, M 8	spring washer, M 8		
0020	2	05094	VTDD10776	Mutter, Sechskant-, M 8	hexagonal nut, M 8		
0021	1		PMVR01242	Schwenkwinkel, Premium Linie	swivel angle, Premium Line		
0022	2	75018	VTVT00458	Schraube, Sechskant, M 10 x 35	hexagonal screw, M 10 x 35		
0023	2	05116	VTRS00505	Scheibe, Unterleg-, M 10	washer, M 10		
0024	2	05115	VTRS00509	Scheibe, Unterleg-, M 20	washer, M 20		
0025	2	12370	RTRT00049	Ablenkrolle	guide roller		
0026	2	12469	LAFN01316	Buchse, 15/2 x 5 x 17,2mm, M 10	spacer sleeve, 15/2 x 5 x 17,2mm, M 10		
0027	2	05116	VTRS00505	Scheibe, Unterleg-, M 10	washer, M 10		
0028	2	05260	VTVT17344	Schraube, Sechskant, M 6 x 50	hexagonal screw, M 6 x 50		
0029	2	05119	VTRS00041	Scheibe, Unterleg-, M 6	washer, M 6		
0030	2		LAFN40138	Abstandshülse, für Stützrolle	sleeve for squeegee wheel		
0031	2		RTRT00379	Stützrolle am Saugfuss	squeegee wheel		
0032	2	05119	VTRS00041	Scheibe, Unterleg-, M 6	washer, M 6		
0033	2	05218	VTDD86633	Mutter, Sechskant-, selbstsichernd, M 6	hexagonal nut, selfsealing, M 6		
0034	2	05220	VTDD86484	Mutter, Sechskant-, selbstsichernd, M 8	hexagonal nut, selfsealing, M 8		
0035	2	05118	VTRS00503	Scheibe, Unterleg-, M 8	washer, M 8		
0036	2	24008		Halter für Stützrolle	support for squeegee wheel		
0037	2	05118	VTRS00503	Scheibe, Unterleg-, M 8	washer, M 8		

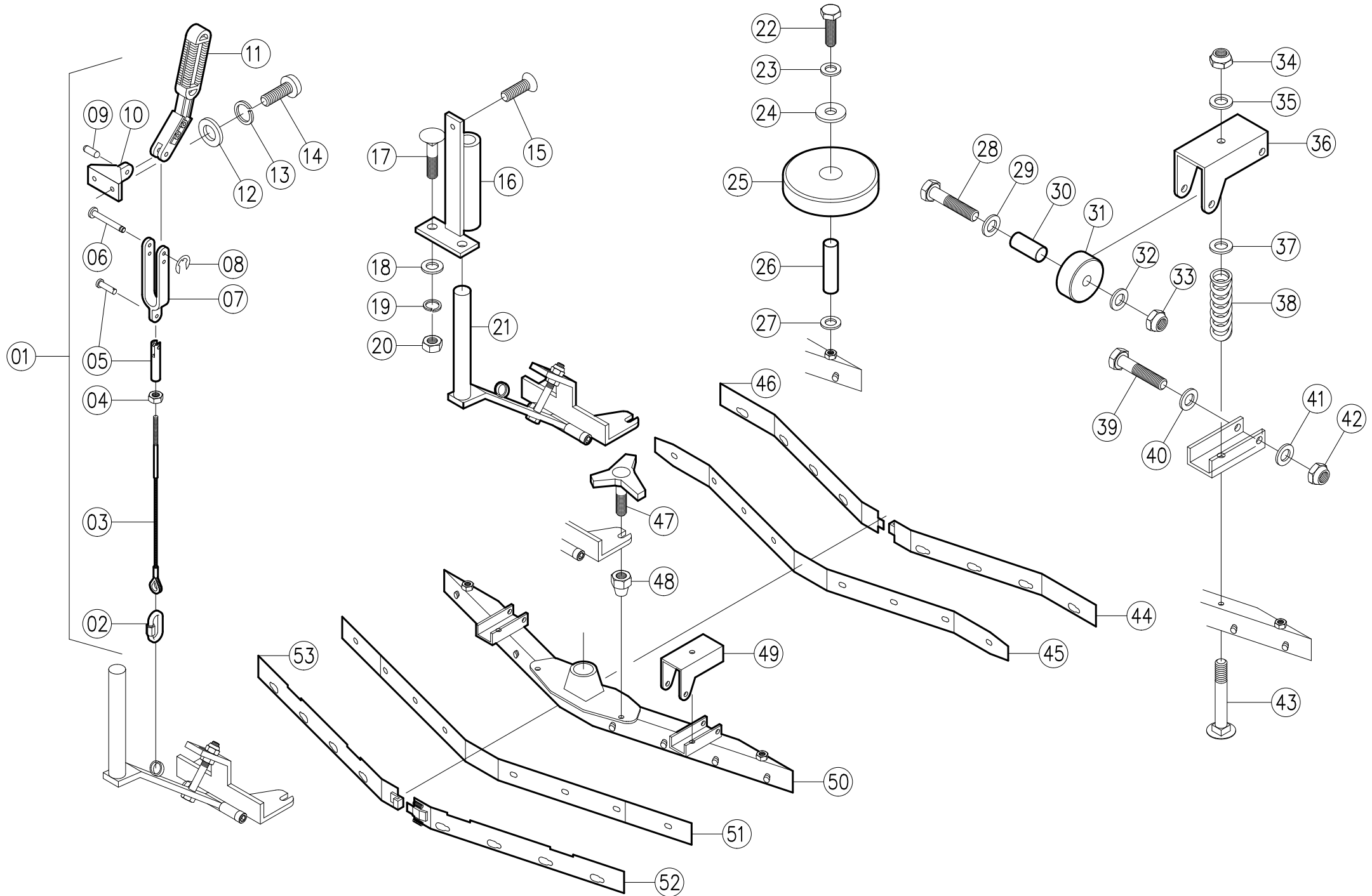

0038	2		MLML49422	Feder an Stützrolle	spring for squeegee wheel		
0039	2	05260	VTVT17344	Schraube, Sechskant, M 6 x 50	hexagonal screw, M 6 x 50		
0040	2	05119	VTRS00041	Scheibe, Unterleg-, M 6	washer, M 6		
0041	2	05119	VTRS00041	Scheibe, Unterleg-, M 6	washer, M 6		
0042	2	05218	VTDD86633	Mutter, Sechskant-, selbstsichernd, M 6	hexagonal nut, selfsealing, M 6		
0043	2	05004	VTVT01304	Schraube, Sechskant, M 8 x 40	hexagonal screw, M 8 x 40		
0044	1	24009		Klemmwinkel, vorne, rechts, SF 50/57cm	clamping angle,front,right,squeeg. 50/57cm		
0045	1	24010		Klemmwinkel, vorne, links, SF 50/57cm	clamping angle,front,left,squeeg. 50/57cm		
0046	1		MPVR45194	Sauglippe, vorne, SF 50/57cm	squeegee blade front, squeegee 50/57cm		
0047	2		MPVR05265	Sternschraube, M 8	Knob for squeegee fastener, M 8		
0048	2	16383	VTAE00074	Blindnietmutter, M 8	blind rivet nut, M 8		
0049	2	24008		Halter für Stützrolle	support for squeegee wheel		
0050	1	24011		Saugfusskörper, SF 50/57cm	squeegee body, for squeegee 50/57cm		
0051	1		MPVR45195	Sauglippe, hinten, SF 50/57cm	squeegee blade rear, squeegee 50/57cm		
0052	1	24012		Klemmwinkel, hinten, rechts, SF 50/57cm	clamping angle,rear,right,squeeg. 50/57cm		
0053	1	24013		Klemmwinkel, hinten, links, SF 50/57cm	clamping angle,rear,left,squeegee 50/57cm		



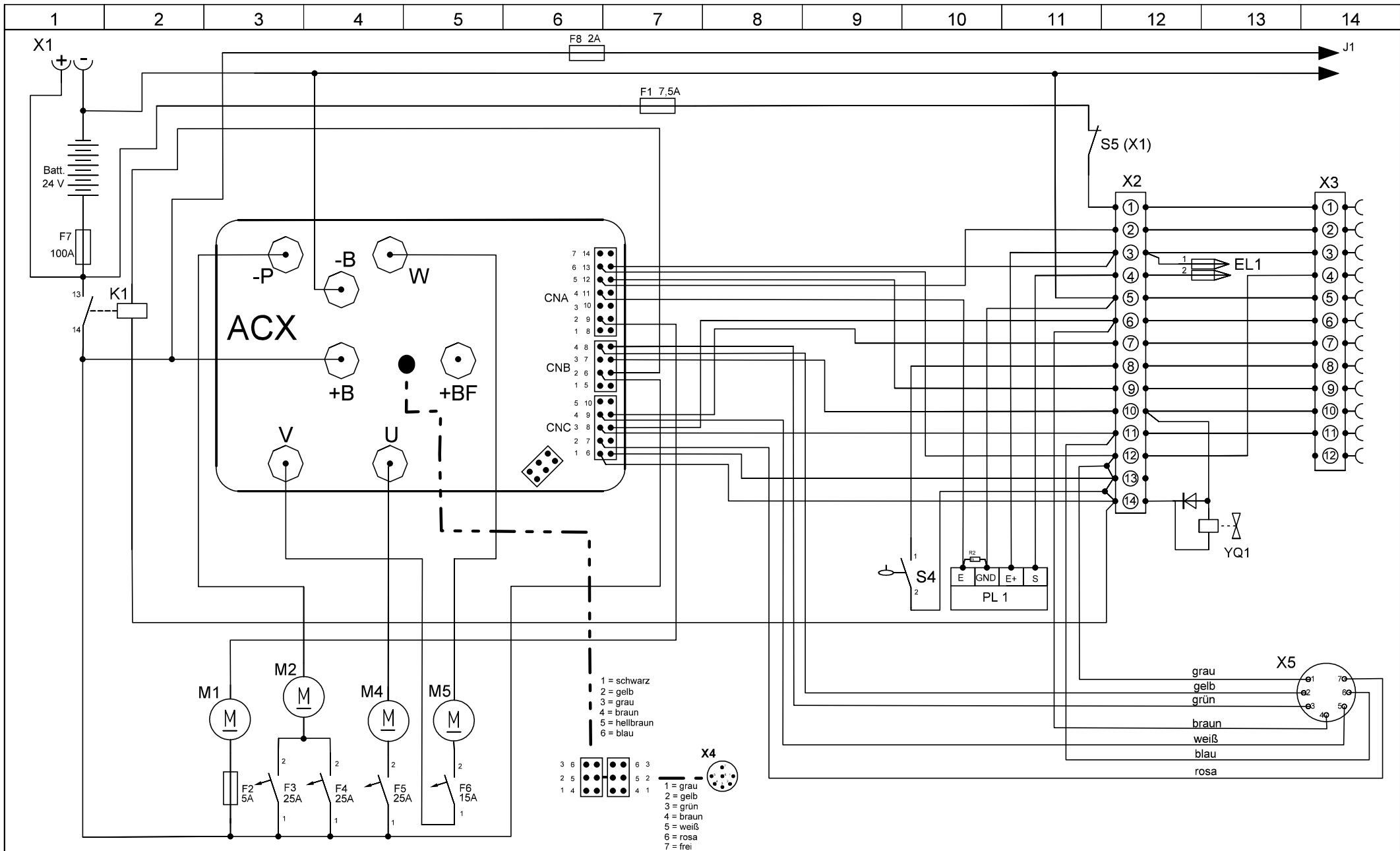

Änderungen/ Modification		Name	Datum/ Date	IP Gansow GmbH Dreherstrasse 9 59425 Unna Tel.:/ phone: 0049 (0) 1801 426769	Projekt/ project  <b>61 BF 57</b>	Blatt/ Page
Name	Datum/ Date	gez.: E. Müller	14.04.2011			2
Revision:	1.0	gepr.:			von/ of 4	

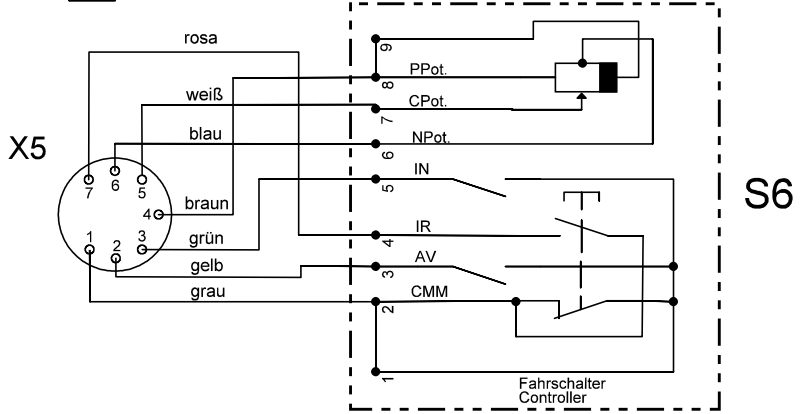
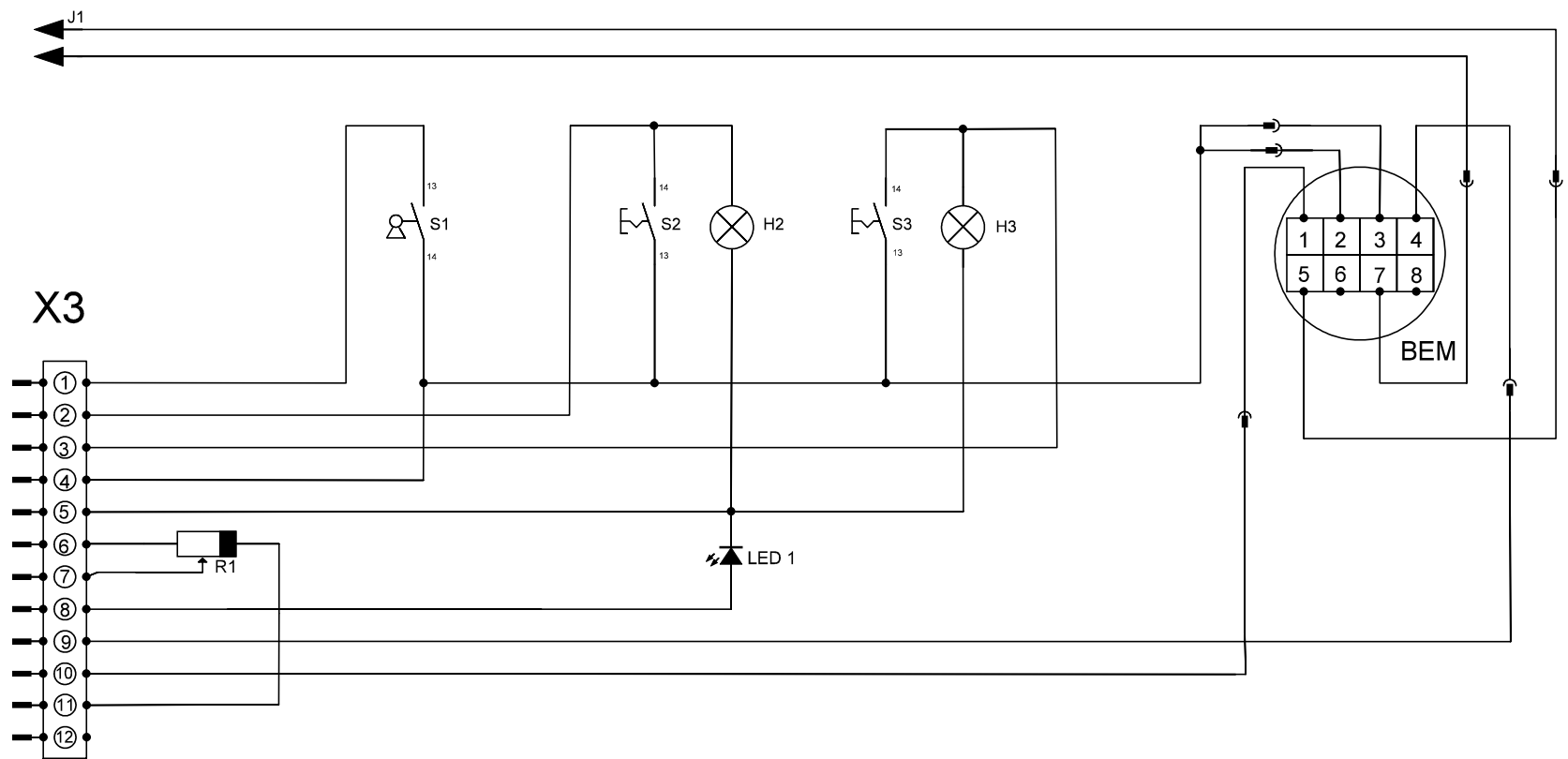

Änderungen/ Modification		Name	Datum/ Date	IP Gansow GmbH Dreherstrasse 9 59425 Unna Tel.:/ phone: 0049 (0) 1801 426769	Projekt/ project  <b>61 BF 57</b>	Blatt/ Page
Name	Datum/ Date	gez.: E. Müller	14.04.2011			3
Revision: 1.0		gepr.:				von/ of 4

1	2	3	4	5	6	7	8	9	10	11	12	13	14
---	---	---	---	---	---	---	---	---	----	----	----	----	----

# Materialliste/ List of components

Nr.:	Anz.	Name	Beschreibung	Bezug	Art. Nr.	Name	Description
Pos.	Qty.			Refer.	Part Code		
1	1	Gansow ACX	Steuerung	ACX	16821	Gansow ACX	Controller
2	1	Batteriekapazitätsüberwachung	Bürstenmotorabschaltung	BEM	16278	Battery discharge indicator	Switching off brush motor
3	1	Batterie		Batt.		Battery	
4	1	Elektroden	Schmutzwasserdetektor	EL1		Probes	Foam/ dirty water detector
5	1	Schmelzsicherung 7,5A	Steuersicherung	F1	70241	Fuse 7,5A	Control fuse
6	1	Schmelzsicherung 5A	Wasserpumpe	F2	70165	Fuse 5A	Waterpump
7	2	Sicherungsautomat 25A	Bürstenmotor(en)	F3/ F4	14643	Circuit breaker 25A	Brushmotor(s)
8	1	Sicherungsautomat 25A	Saugmotor	F5	14643	Circuit breaker 25A	Vacuum motor
9	1	Sicherungsautomat 15A	Fahrmotor	F6	14693	Circuit breaker 15A	Traction motor
10	1	Polsicherung 100A	Hauptsicherung Batterie	F7	06919	Pole fuse 100A	Main fuse, battery
11	1	Schmelzsicherung 2A	BEM	F8	70164	Fuse 2A	BEM
12	1	Meldeleuchte	Bürsten Ein/ Aus	H2	06345	Pilot lamp	Bush on/ off
13	1	Meldeleuchte	Saugmotor Ein/ Aus	H3	06345	Pilot lamp	Vacuum on/ off
14	1	Schütz/ 124A	Saugmotor	K1	06328	Contact/ 124A	Vacuum motor
15	1	LED	Reinwasser leer	LED1	11738	LED	Solution tank empty
16	1	Wasserpumpe	Wasserpumpe 24V	M1	16807	Waterpump	Waterpump 24V
17	1	Bürstenmotor	Bürstenmotor 24V	M2	13530	Brush motor	Brush motor 24V
18	1	Saugmotor	Saugmotor 24V	M4	01293	Vacuum motor	Vacuum motor 24V
19	1	Fahrmotor	Fahrmotor 24V 200W	M5	13528	Traction motor	Traction motor 24V 200W
20	1	Schaumabschaltung	Abschaltung des Saugmotors	PL 1	14254	Foamcontrol	Switch off vacuum motor
21	1	Potentiometer 22kOhm	Wassermenge	R1	06154	Potentiometer 22kOhm	Water quantity
22	1	Widerstand 1kOhm	Schaumabschaltung	R2		Resistor 1kOhm	Foam Control
23	1	Schlüsselschalter	Maschine An/ Aus	S1	KTRI15039	Key switch	Machine on/ off
24	1	Schalter Bürste	Bürste An/ Aus	S2	KTRI15038	Switch brush	Brush on/ off
25	1	Schalter Saugmotor	Absaugung An/ Aus	S3	KTRI15040	Switch vacuum motor	Vacuum on/ off
26	1	Schwimmerschalter	Reinwasser leer	S4	MECI00516	Float switch	Solutiontank empty
27	1	Mikroschalter Batteriestecker	Maschinen Stop bei Laderverbindung	S5	16433	Microswitch batterieplug	Machine stop during charging
28	1	Fahrschalter	Antrieb Vorwärts/ Rückwärts	S6	14255	Traction controller	Traction forward/ backward
29	1	Batteriestecker	50A	X1	11333	Batterieplug	50A
30	1	Klemmleiste		X2		Terminal block	
31	1	Kupplung/ Stecker	Steckverbinder	X3	31236/ 31237	Connector/ plug	Pin/ socket connector
32	1	Kupplung/ Stecker	Programmierschnittstelle	X4	16397	Connector/ plug	Programming interface
33	1	Kupplung/ Stecker	Steckverbinder Fahrschalter	X5	06785/ 16395	Connector/ plug	Pin/ socket connector Traction controller
34	1	Magnetventil		YQ1	13195	Solenoid valve	
35							

Änderungen/ Modification		Name	Datum/ Date	IP Gansow GmbH Dreherstrasse 9 59425 Unna 	Projekt/ project  <b>61 BF 57</b>	Blatt/ Page
Name	Datum/ Date	gez.: E. Müller	14.04.2011			4
		gepr.:				von/ of
Revision:	1.0			Tel.:/ phone: 0049 (0) 1801 426769		4