

Contents

	Page
1. General Information	3
1.1. Important safety advice.....	3
1.2. Guidelines for the operator	3
1.3. Transporting the Machine	3
1.4. Electrical connection.....	3
2. Preparation for use.....	4
2.1. Bag Installation.....	4
2.2. Brush Height adjustment.....	4
3. Operation.....	5
3.1. Starting the machine.....	5
4. Maintenance	5
4.1. Filter replacement.....	5
4.2. Belt adjustment/replacement	5
5. Storage.....	6
6. After sales storage.....	6
7. Guarantee.....	6
8. Waste Electrical & Electronic Equipment.....	6
9. Technical specification	6
10. Accessories.....	7
11. Fault diagnosis.....	7
12. Declaration of conformity.....	8

IMPORTANT

BEFORE USE READ THESE INSTRUCTIONS AND RETAIN FOR FUTURE REFERENCE

1. General information

The VWAV cleaner is designed for the collection of dust in indoor areas. It should not be used in outdoor areas.

The following instructions contain important information about the machine and safety advice for the operator.

Equipment must be operated, serviced and maintained in accordance with the manufacturer's instructions.

If in doubt contact the supplier of your machine.

These instructions are valid for the following model:

VWAV

1.1 Important Safety Advice

When using electrical equipment basic safety precautions should be followed including the following.

- Read all instructions carefully before use.
- Before using the appliance, check that the mains power voltage corresponds with the voltage shown on the data plate.
- Do not leave machine unattended when plugged in.
- Keep children and unauthorised persons away from the machine when in use.
- Do not leave the machine connected to the electricity supply when not in use, always remove the plug from the socket-outlet.
- Do not operate switches or touch the mains plug with wet hands as this may cause electric shock.
- Switch off the machine before removing the plug.
- When unplugging pull the plug, not the supply cord.
- Do not operate the machine with a damaged supply cord or plug, or after the machine malfunctions or is damaged in any way. Contact an authorised Service Agent for repair or adjustment.
- The plug of the power supply must be removed from the socket-outlet before commencing cleaning of the machine or undertaking maintenance operations.
- The power supply cord must be regularly inspected for signs of damage. If the power supply cord is damaged, it has to be replaced.
- Do not use to pick up moisture or any liquids.
- Do not use where hazardous dust is present.
- Do not use in an explosive atmosphere.
- Do not use to vacuum up sharp objects.
- Do not pick up oil or other flammable material.
- Take care when using machine near the top of stairs to avoid overbalancing.

- Do not use the appliance to vacuum lighted cigarettes, hot ashes and other combustible objects,
- **Do not** use the appliance to vacuum tiny particles like cement or plaster dust as this will shorten life of the motors.
- **Do not** block air flow, blocking the suction in any way (blocked filters, blocked hose or full dust bag) will decrease the efficiency and will shorten the life of motor.
- **Do not** run the vacuum cleaner over the power cable.
- **Keep hair**, loose clothing, fingers and all parts of body away from openings and moving parts.

1.2 Guidelines for the operator

- Only use the machine on firm level surfaces.
- Operators must be fully trained in the use of the machine in accordance with these instructions and be able to perform user maintenance.
- Operators should be physically capable to manoeuvre, transport and operate the machine.
- Operators should be able to recognise unusual operation of the machine and report any problems.
- Wear suitable footwear to avoid slipping.
- Wear suitable clothing to keep dry and warm.
- Where possible implement job rotation and adequate rest periods to avoid continuous use of the same muscles.
- **Do not** leave the machine running unattended
- **Do not** smoke when using the machine.
- **CAUTION** - This machine is for indoor use only and should not be used or stored outdoors or in wet conditions.

1.3 Transporting the machine

When transporting a machine ensure that all components, accessories and removable parts are securely fastened and that the supply cord and plug are not trailing.

Take extreme care when moving a machine up or down steps.

1.4 Electrical connection

Before connecting the machine to the power supply check that your supply voltage corresponds with that marked on the rating label on the rear of the machine.

The power supply cord plus any extension leads should not exceed 40m in total. The cross-section of any extension cable wiring must be at least 2,5mm².

UK only

The supply cord for 230V models is fitted with a plug containing a 13 amp fuse. Should the fuse require replacement it must be replaced by a 13 amp fuse conforming to BS11362, and the fuse cover must be refitted. If the fuse cover is lost the plug must not be used until the correct replacement cover is fitted.

IMPORTANT – if the supply cord is damaged, it must only be replaced by a suitable cord available from the manufacturer or an authorised service agent.

Warning – This appliance must be earthed

2 Preparation for use

- Loosen handle pivot knobs and adjust handle to comfortable operation height



- Tighten knobs to lock handle in place



2.1 Bag Installation instructions

- Open the lid.
- Unzip cloth bag and install paper bag inside.
- Attach both bag openings together onto vacuum intake housing.

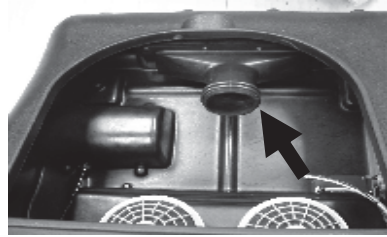

- Make sure bag is properly deployed inside machine housing.
- Completely close zip on cloth bag and close lid of machine.

2.2 Brush Height adjustment

- This machine has 5 brush pile adjustment settings.
- To raise brush height:** Lift up height adjustment bar until desired brush height is attained.

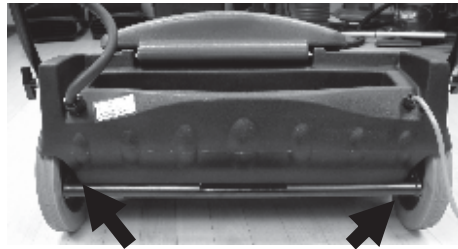

- To lower brush height:** push down on height adjustment bar until desired brush height is attained.

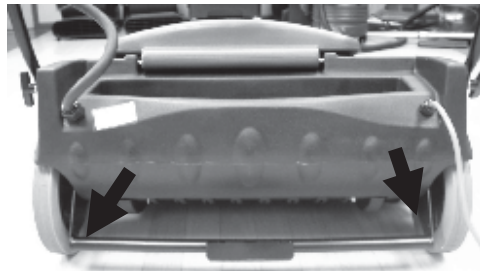

3 Operation of the machine

3.1 Starting the machine

- Operate vacuum motor switch on handle.
- To operate brush squeeze trigger bar.
- Adjust height for proper pick-up (refer to height adjustment instructions and diagram below).



4 Maintenance

WARNING - Before undertaking maintenance operations or adjustments switch off machine and unplug from the electricity supply.

The machine requires minimum maintenance apart from the following checks by the operator.

- **Supply cord** - Regularly inspect sheath, plug and cord anchorage for damage or loose connection.
- **Vacuum filters** - Check the vacuum filters are cleaned and replaced as appropriate.
- **Vacuum head** - Check and remove any debris or lint build-up from the head.

IMPORTANT - All other servicing and repairs should only be performed by a Truvox engineer or Authorised Service Agent.

IMPORTANT - Should the machine fail to operate please refer to the fault diagnosis section in the back of the instruction manual. If the problem / remedy is not listed please contact Truvox Customer Service Department for rapid attention.

4.1 Filter replacement

Remove filter cover screws at back of machine.

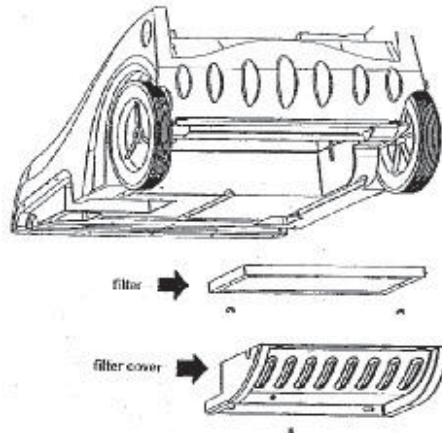

- Remove the two nuts holding filter onto machine.
- Replace filter in proper position and tighten nuts.
- Reinstall filter cover.

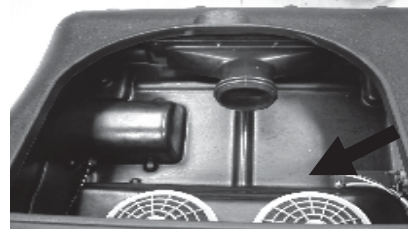

Vacuum filters.

- Lift filter housing from motor and replace filter.
- Reinstall filter housing.

4.2 Belt Adjustment /replacement

- Remove belt cover on left side of machine

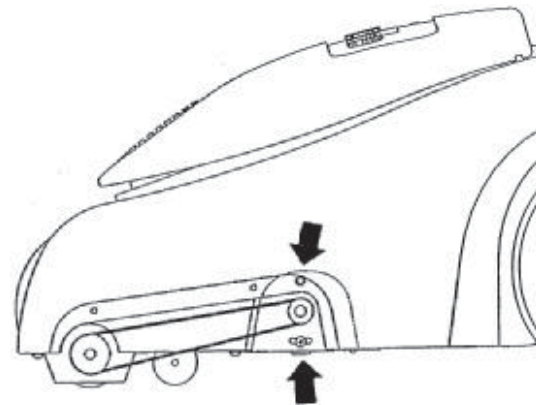

Belt Adjusting Screws

- Loosen the two motor belt adjusting screws on motor bracket.
- Remove belt
- Install new belt and reposition motor to eliminate excess slack.
- Once tension is set, tighten motor adjusting screws.

- Replace belt cover on side of machine.

5 Storage

- Always unplug the machine after use.
- Wrap supply cord around the handle of the machine ensuring that the plug is not trailing on the floor. Store the machine in a dry indoor area only.

6 After Sales Service

Should you require after sales service please contact the supplier from whom you purchased the machine, who will arrange service. Repairs and servicing of Truvox products should only be performed by trained staff. Improper repairs can cause considerable dangers to the user. Enquire about the Truvox low cost and efficient Maintenance Contract.

7 Guarantee

Your product is guaranteed for **one** year from the date of original purchase, or hire purchase, against defects in materials or workmanship during manufacture. Within the guarantee period we undertake at our discretion, to repair or replace free of charge to the purchaser, any part found to be defective, subject to the following conditions.

CONDITIONS

1. Claims made under the terms of the guarantee must be supported by the original invoice/bill of sale issued at the time of sale, or the machine Serial Number.
2. For claims under this guarantee contact the supplier from whom you purchased the product who will arrange the appropriate

action. Do not initially return the product as this could result in transit damage.

3. Neither Truvox nor its distributors shall be liable for any incidental or consequential loss.
4. This guarantee is governed by the laws of England.
5. This guarantee does not cover any of the following:
 - Periodic maintenance, and repair or replacement of parts due to normal wear and tear.
 - Damage caused by accident, misuse or neglect, or the fitting of other than genuine Truvox parts.
 - Defects in other than genuine Truvox parts, or repairs, modifications or adjustments performed by other than a Truvox service engineer or authorised service agent.
 - Costs and risks of transport relating directly or indirectly to the guarantee of this product.
 - Consumable items and wear parts such as drive belts.

This guarantee does not affect your statutory rights, nor your rights against the supplier arising from their sales or purchase contract.

8 Waste Electrical & Electronic Equipment

Do not dispose of this device with unsorted waste. Improper disposal may be harmful to the environment and human health.

Please refer to your local waste authority for information on return and collection systems in your area.

9 Technical specification

All models: 230-240 V ~ 50 Hz, Class I construction. Fitted with 25m supply cord and 13A fused plug.

Model	VWAV	
Code	VWAV	
Voltage	v	230
Vac motor	W	2 x 1000
Vacuum lift	mm	1600
Sound pressure level	dB(A)	70
Size (L x W x H)	cm	50 x 76 x 91
Cable length	m	25
Weight empty	kg	43
Brush width	cm	71
Brush Motor	rpm	1800
Brush height adjustment	5 pile settings	
Drive belt	6 groove Poly-V	
Filtration	4 stage Clean-Air	
Warranty	1 year	

Truvox International is a BSI Registered Company and our policy is one of continuous development. We reserve the right to change specifications without prior notification.

10 Accessories

Part	Part no	Description
Paper Dust bag	90701	Pack of 10 paper bags
Cloth dust bag	19816	Cloth bag
Filter	19855	Secondary filter
Filter	30088	Vacuum inlet filter

11 Fault Diagnosis

Problem	Reason	Remedy
The Vacuum does not work	<ul style="list-style-type: none">• Power failure.	<ul style="list-style-type: none">• Check the main fuse, the power supply cord and the plug.• Check and reset 10 Amp cutout located on handle.
The brush does not rotate	<ul style="list-style-type: none">• Power failure• Damaged belt• Obstructions present	<ul style="list-style-type: none">• Check the main fuse, the power supply cord and the plug.• Check and reset 3 Amp cutout located on handle.• Removed side cover and check belt. Replace as necessary• Remove obstruction

* If the fuse blows several times, the machine should be checked by an authorised Service Agent.